

PGA Club Racing

NEWS

VOLUME 25 • EDITION 17.3 • SPONSORED BY PORSCHE CLUB OF AMERICA



PAGID
RACING
THE DIFFERENCE IN BRAKING



THE FIRST CHOICE FOR CHAMPIONS

**MAXIMUM PERFORMANCE
AND RELIABILITY**



ORDER
**THE PADS
YOU NEED**

In Stock, All the Time, Shipped Free

WE'RE THE LARGEST U.S. PAGID RACING BRAKE PAD SUPPLIER, WITH THE MOST EXTENSIVE INVENTORY.

PAGID Racing Brake Pads are available in many compounds to fit most applications.

Call us now or use the **PAGID Racing Brake Pad Quick Search** on our website to find the pads you need >>> **FAST!**

PAGID Racing brake pad compounds offer maximum stopping power, ultimate endurance and consistently high quality for professional and amateur racers alike. EXPERIENCE THE DIFFERENCE IN BRAKING!

ORDERS 800.356.2080 TECH SUPPORT 847.304.5515 ONLINE NORTHSTARMOTORSPORTS.COM

www.pagidracings.com

Northstar
MOTORSPORTS
The Original Racing Resource.™

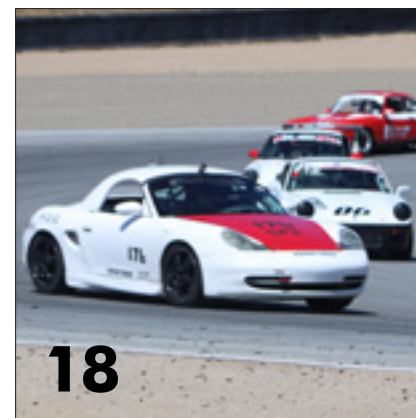

FEATURES

- 4 E - Stock — E is for extra (fun)
- 12 Spec 911s Racing at Laguna Seca
- 18 Laguna Seca Spec Boxsters
- 22 Entering AutoClub Speedway — A Different World
- 32 Racecraft
- 34 My First Rookie Club Race
- 40 Le Mans: Three-peat
- 42 The Dream Once Stolen
- 46 Original Owner Spec Boxster Project
- 54 Road (racing) Trip
- 62 Money, Beauty and HP
- 68 Historicizing Porsche: The Russian Connection
- 72 Twilight Cycling at Laguna Seca

COLUMNS

- 26 From the Chair
- 28 View From the Tower
- 38 Editorial License
- 60 Coaching Perspective

REMNANTS

- 9 2017 Club Racing Schedule
- 24 PCA Vintage Racing
- 52 2017 Club Racing National Sponsors
- 61 PCA Club Racing Contingency Programs
- 70 Event Ads Index
- 74 2017 Hard Chargers
- 76 Classifieds
- 78 Club Racing National Committee, Advertising Index, CRN Staff

On the Cover: Photographer Ken Hills took this shot at the Sunday race start for E-Stock at Watkins Glen

Club Racing News (CRN) is the official publication of the Porsche Club of America, Club Racing, and is published quarterly. Written contributions and photographs are welcome and can be mailed to the editor. Opinions expressed are those of the authors and do not necessarily represent the official position of the Porsche Club of America, Club Racing National Committee, its officers or members. Permission is granted to reproduce any material herein provided full credit is given to the author and PCA Club Racing News. PORSCHE®, the Porsche Crest®, CARRERA®, TARGA®, Cayman® and Boxster™ are trademarks of Porsche AG. The editor shall reserve the right to edit and publish only those articles felt to be in the best interest of the members of the Porsche Club of America. Commercial advertising inquiries should be directed to the CRN Advertising Coordinator. Postmaster: Address Change to: PCA Club Racing News, c/o PCA Executive Secretary, P.O. Box 6400 Columbia, MD 21045



E IS FOR EXTRA (FUN) E IS FOR EXCELLENCE

POSSIBLY THE LARGEST GROUP OF E-STOCK 911'S AT WATKINS GLEN

STORY BY JIM BUCKLEY & PAT HEPTIG, PHOTOS BY KEN HILLS & SKIP CARTER

The letter E stands for many things in the English language, but for E-Stock PCA club racing it stands for Excitement, Excellence, and Extreme competition. On the June 2-4 weekend over 250 Porsche race cars converged on Watkins Glen and E-Stock brought out the second largest class with 30 entries. The best E-Stock drivers from around the country converged on the Glen to compete for bragging rights for the year (or at least until Road America)!

Why is E-Stock so popular? The majority of the class is run with 1980s 911 Euro spec SCs and '84-'89 911 Carreras, which are consid-

ered by Porsche purists to be the last air-cooled Porsches true to the original 911 lineage, and they are just *very* cool to own and drive spiritedly. They have torsion bars for springs and only make 200 to 220 hp, but handle so well that they are faster than most of the younger and higher-powered F and G cars.

Very predictable handling makes a very fun and safe car to drive fast. Don't kid yourself. While they may have a stock engine and stock brakes, these E-Stock race cars are equipped with race suspensions, race wheels, and run on sticky Hoosier race tires. When driven at or near the limit,

these cars are a blast.

At the Glen the level of competition in E-Stock escalated quickly with Jim Buckley breaking Evan Close's 2016 track class record by 0.5 seconds in the second practice session on Friday. That set the tone as the record continued falling throughout the weekend. By Saturday afternoon Dan Martinson had turned a 2:07.659 in his 1981 911 Euro SC, which is faster than the F stock and G stock records and 1.5 seconds faster than last year. E-stock is so popular it is attracting some of the best drivers in the country, and for good reason.



Above: All of the E-Stock cars and drivers we were able to gather

Left: race start - Clarke Simpson, Dan Martinson, Evan Close (2016 record holder) and Niels Meissner (who borrowed car from his dad)



Left: Jeff Wiggins and Pat Heptig. Tell me there's no competition there!

After Day 1 the PCA scrutineers stepped up their game and brought out a precision borescope to inspect fuel and air intake systems and intake ports. This is just one of several new tools being implemented. Several violations were discovered and some 13/13 sanctions were made. These inspections are welcomed by the racers to ensure a level playing field in a highly competitive arena.

The first sprint race started and finished with Dan Martinson on the pole and taking P1. P2 went to Clarke Simpson, and Niels Meissner finished in P3. Evan Close took P4 and Pat Heptig took P5. Racers started Sprint 2 (the first championship points race of the weekend) gridded by their fastest lap from Sprint 1. Martinson again led from the pole and finished P1. Simpson and Meissner again finished P2 and P3, respectively. Heptig took P4 and Doug Crossman took P5.

Sunday brought rain and significantly reduced the grip levels on the track for the 1.5 hour long enduro (the second championship points race). The rain (and the Glen's reputation for being treacherous in the wet) and attrition from the first two sprint races reduced the number of cars in the E class field for the enduro.

In the rain, visibility is greatly reduced and traction is compromised. It is an exercise in (hopefully) controlled sliding and driving strange lines to find the most traction through each corner. Martinson again, despite a few spins, was able to lay down consistently faster laps and brought home the win.

Meissner showed his consistency in both wet and dry conditions, taking P2 with no issues. Chip Eggleton took P3 and Christopher Fahy took P4, and the driver combination of Steven Dimakos and Steve Anderson took P5.

If you like good, clean competition and want to experience true *old school* Porsche 911 racing with some of the best drivers in the country, E-Stock is the place to be! 🏁



Scott Bresnahan

We tried to get all of the E-Stock cars and drivers for a photo op on Friday and Saturday. We did pretty good, better on Saturday, but there were always cars torn down, on the trailer or otherwise missing. Two of the cars for our shot were actually towed for the shot. Our apologies to any that we missed.

left: Chip Eggleton leads Cameron Best (223)

below: The E-Stock drivers we were able to get together Saturday

Phone: 203-723-8928

www.SoftronicSoftware.com

email: Info@SoftronicSoftware.com



Softronic® is the leading producer of racing and street performance software.



Softronic®-tuned cars have won the GT Class at the Rolex 24 at Daytona and powered every car in the Cayman Interseries.

Softronic® software has also powered winning cars and top finishers in the ultra-competitive World Challenge Series, Continental Tire SportsCar Challenge Series, and PCA races from coast to coast.

Street or track, Softronic® software helps you put the competition in your rear view mirror.



Spencer Cox at the wheel of his GTB1 National Championship-winning Cayman. Enhanced with Softronic® software.



While most E-Stock cars are 911s, not all are:

left:
Tom Hamilton
1986 944 Turbo

right:
Clarke Simpson
1978 911SC



left:
Gene Raymondi
2004 Boxster

right:
Dan Martinson
1978 911SC Euro



left:
Frank Osborn
2004 Boxster

right:
Chris Fahy
1986 944 Turbo



left:
Doug Crossman
1984 911

below:
Friday morning driver's meeting conducted by stewards Bill Miller & Mike Hoke



2017 Club Racing Schedule

DATES	EVENT / ADDITIONAL INFO	REGION/ZONE	EVENT/CONTACT
Jul 8-9	Putnam Park* 944 Cup Midwest	Ohio Valley	Rich Rosenberg 513.317.7911 rjrol@aol.com
Jul 14-16	Monticello Motor Club* 944 Cup North / Cayman GT4CS East Series Races	Riesentöter	Chris Karras 215.850.4040 rtr-racechair@nazg.com
Jul 29-30	Brainerd International Raceway* 944 Cup Midwest	Nord Stern	Dave Sorenson 952.807.1414 dsorenson@leancultureinc.com
Aug 4-6	Canadian Tire Motorsports Park* 944 Cup North / Cayman GT4CS East Series Races	Upper Canada	Terry Casson 613.848.1301 club-race@pcaucr.org
Aug 18-20	New Jersey Motorsports Park* 944 Cup North	Schattenbaum	Dan Petchel 609.298.2277 carsinc@comcast.net
Sep 2-3	Thunderhill Raceway 944 Cup West / West Coast Series	Golden Gate	Richard French 650.995.6100 rf@richardfren.ch
Sep 2-4	Road America* 944 Cup Midwest	Chicago	Keith Clark 630.514.5937 kc_design@sbcglobal.net
Sep 15-17	Utah Motorsports Campus* 944 Cup West	Intermountain	Ed Mineau 801.597.3037 emineau@comcast.net
Sep 15-17	NOLA Motorsports Park* 944 Cup Southwest / Cayman GT4CS East Series Races	Mardi Gras	John Crosby 504.909.2767 jlcrosby@crosbydevelopment.com
Sep 30-Oct 1	Willow Springs International Park* 944 Cup West / West Coast Series	San Diego	Greg Phillips 619.395.7506 phigreg@gmail.com
Oct 7-8	Hallett Motor Racing Circuit	Cimarron	Jon Jones 918.200.4044 cimarronpca.events@gmail.com
Oct 13-15	Pittsburgh International Race Complex* 944 Cup Nationals East (M) (N) (S) / Vintage Run Group	Allegheny	Bill Sulouff 412.496.2501 clubrace@ARPCA.com
Oct 27-29	Daytona International Speedway* 944 Cup South / Cayman GT4CS East Series Races	Zone 12	Steve Williamson 407.435.0344 steve@stevewilliamson.com
Nov 11-12	Motorsport Ranch* 944 Cup North/West/Southwest / Vintage Run Group	Maverick	Pat Heptig 214.649.7909 pheptig@heptiglaw.com
Nov 11-12	Buttonwillow Raceway Park 944 Cup West / West Coast Series	San Diego	Greg Phillips 619.395.7506 phigreg@gmail.com

* Indicates an Enduro

DON'T JUST TAKE CURVES.
OWN THEM.



©2017 KW automotive North America, Inc. All rights reserved.

Experience perfection, enhanced by performance. The patented KW competition 3-way coilover system, with independently adjustable compression and rebound, lets you dial in the precise response and feel of enhanced performance while providing ultra quick chassis settling for true track performance. Our passion for perfection shines through in our quality components, like INOX stainless steel or race-grade aluminum components and precision click adjusters. **To order, visit KWsuspensions.com, and take every curve with confidence.**

competition

INDEPENDENTLY
ADJUSTABLE
REBOUND AND
COMPRESSION
DAMPING





PORSCHE SPEC 911 RACING AT LAGUNA SECA

STORY BY TED LIGHTHIZER; PHOTOS BY TED LIGHTHIZER AND STEPHEN KRUPNICK

The Spec 911 racing series was the brain child of long time Porsche race car driver and car builder Rich Walton, owner of Jerry Woods Enterprises (JWE Motorsports) one of the San Francisco Bay area's premier Porsche race facility located in Campbell, CA. JWE Motorsports is a state of the art race shop set up to handle all issues associated with racing Porsches including personal in-car coaching from winning Porsche drivers like Johannes Van Overbeek, Thomas Merrill and Rich Walton.

Spec 911s are based on the classic, long wheelbase air-cooled Porsche 911s from '69 to '89. SCs and Carreras are the most popular built from '78 to '89 because they have either the 3.0L or 3.2L required motors that are normally aspirated. No turbos. A number of intake upgrades are allowed, like PMO carbs to the 3.0L engine, but the 3.2L engine must

use the stock single butterfly intake. With stock bore and stroke and a 9:1 compression ratio, the motors easily generate 250hp at the rear wheels and are a little faster in overall speed and performance when compared to the infamous '74 911 RSR.

Both the 915 and G-50 5-speed manual transaxles with limited slip differentials are allowed. All cars must use the same wheel and tire package: Toyo RA-1s with 8x16 rear wheels and 7x16 up front. Suspension will get upgrades to torsion bars, shock absorbers, anti-roll bars and stiffer springs.

Modifications to body or "tub" would be an integrated roll gage designed specifically for the 911. Racing seats with either a 5 or 6 point harness belt system that is compatible with an approved neck restraint device and a driver's side window net are essential along with an on-

board fire suppression system. Overall weight of a Spec 911 race car is approximately 2200 lbs thanks to a Plexiglas rear window, fiberglass rear spoiler and gutted interior. The minimum weight requirement for a Spec 911 with driver is 2350 lbs.

Now let's talk about the major players involved in Spec 911 racing on the West Coast: PRC (Porsche Racing Club), an offshoot from PCAs Golden Gate region about ten years ago, actually created the Spec 911 class. The premier shop involved with PRC is Jerry Woods Enterprises (JWE Motorsports). Those of you with longer memories might remember Jerry Woods as one of the premier engine builders during the heyday of IMSA racing in the late '70s through '90s. His engines won dozens of races and even helped propel Bob Garretson to the World

Endurance Driver's Championship in 1981. It seemed that the Porsche factory even wondered how he made so much reliable power.

Okay, now that we know how the Spec 911 race car is setup, let's go watch them race. The fourth stop on the 2017 PCA Club Racing West Coast Series was held June 2-4 at the legendary Mazda Raceway Laguna Seca on its infamous 2.23 mile, 11 turn road racing circuit. The WCS consists of PCA races pretty much west of the Rockies (with High Plains just being a little out of that envelope). Weather was perfect all weekend, clear sunny skies with temps in the mid 70s.

Seven Spec 911s competed in three 30 minute sprint races with the entire field of 50 PCA club race drivers on Saturday and Sunday. The Spec 911 Sprint Race 1 results: Ross Merrill's #52 '82 911 had fastest lap at 1:43 followed by David Higgins' #40 '75 911 at 1:44, then Sean Neel's #46 '81 911 at 1:45.

Sprint Race 2 on Sunday had 49 Porsches, including seven Spec 911s who all finished the 30 minute race with the fastest being Robert Murillo #82 '85 911 Carrera at 1:41.

Sunday's final Sprint Race 3 had a field of 36 Porsches with six Spec 911s. The fastest Spec 911 was again Robert Murillo, who finished 12th overall with a lap time of 1:41. Right behind Robert was Behram Soonawala's #81 '75 911 followed by Sean Neel. The entire field of six Spec 911s ran under a three second blanket with very close and exciting racing throughout the weekend. All drivers showed good on-track judgement with lots of give and take with no major incidents, kudos drivers.

Kudos to all the drivers and also to all the volunteers from the PCA Golden Gate Region and their Club Racing Chair, Richard French. Also to be congratulated are PCA Club Racing Steward Vicki Earnshaw, Scrutineer Jeff Burger for keeping the racers informed and safe all weekend long and Timing Tech Chuck Pirelli for handling all that goes along with that job. 🏁



Spec 911 drivers: Robert Murillo, David Higgins, Brian Lynch, Sean Neel, Ross Merrill and Bill Ward.

Not in the photo: Behram Soonawala,



David Agretelis passes Andy Kwitowski (in the dirt) with Laura Ely and Chris Murry behind



John Nelson was also a winner



John Ball leads Bruce Blockus and John Nelson to the Corkscrew



left: Club Racing staff included Scrut Jeff Burger, Steward Vicki Earnshaw and Timing Tech, Chuck Pirelli



right: Doug Baron Pirelli award for winning GTC classes



left: Philip Strong recieved GT Racing prize



right: Andrea Correll received gift from Trailex Aluminum Trailers



left: Isabella Busalacchi did well in SP1



right: John Nelson received the Worker's Choice award



right: David Agretelis received the other Worker's Choice Award



left: Patrick Sloan enjoyed his first trip to Laguna Seca



right: functional art



WE ARE FAST AND STEADY AND ONLY BRAKE WHEN WE HAVE TO.

PROXES

High Performance That Never Rests.

Proud partner of Club Racing PORSCHE CLUB OF AMERICA

WE ARE TOYO. ALL OR NOTHING. TOYOTIRES

©2015 Toyo Tire U.S.A. Corp.



left:
Behran
Soonawala



right:
Bill Ward



left:
Mike Gaulke



right:
David Higgins



left:
Sean Neel



right:
David Agretelis



left:
Robert Murillo



right:
Brian Lynch



left:
Ross Merrill



right:
Tim Smith dis-
cussing passing
strategy with
Chris Hamilton

Allegheny Region PCA presents...
The Steel Cities Championships at



Das Burghring



Oktober 13-15 at Pittsburgh International Race Complex

- Full 2.8 Mile Course
- Repaved in 2017 !
- Thursday Test Day
- Awards Banquet
- Oktoberfest Dinner
- Vintage Racing Group
- 944 Cup East Championship



Registration opens Aug. 28th.
Oktober 12th Test n Tune
Oktober 13-15
Practice, Sprints, Enduros



For more info contact:
Bill Sulouff: ClubRace@ARPCA.com
web: www.ARPCAClubRace.com

The birthplace of PCA Club Racing presents:



ROCK THE SUMMIT
SPORTS
Club Race

SEPTEMBER 22nd, 23rd & 24th

VINTAGE RACING is back...

and so is our famous DIXIE BONES BBQ!!!



REGISTRATION OPENS AT:
HTTP://REGISTER.PCA.ORG
ON AUGUST 7TH, 2017 - 10PM EDT



LAGUNA SECA SPEC BOXSTERS

FROM PODIUM TO DEAD LAST IN ONE WEEK — I KEEP COMING BACK TO PCA CLUB RACING

STORY BY DOUG BOCCIGNONE; PHOTOS BY STEPHEN KRUPNICK & TED LIGHTHIZER

During the drive north on I-5 from Buttonwillow, I was feeling pretty good. Another three-day race weekend with my Nor Cal SPB friends was in the books with three podium finishes in field of 8-10 SPB racers. The only significant wrenching I did was on my competitors' cars, including a gearbox swap and half-shaft replacement for the guys who finished in front of me. That's part of the fun and camaraderie of SPB racing. That kind of help from my buddies, often working late under the shop lights, has made the difference between packing up and heading home or getting to race the next day many times.

On this Sunday evening, while tired, I was happy to know that in five short days I'd be in my car again racing at Laguna Seca.

On Memorial Day, I set a personal best for pre-race load-in by merely backing my trailer into the side yard and putting the cover on the race car (I'll take my victories where I can get them!). A few days later I just needed to add water and food to the motorhome and I was ready to head down to venerable Laguna Seca on Thursday afternoon.

We arrived Thursday evening at the crowded Mazda Raceway Laguna Seca paddock for an event that wasn't a typical PCA race weekend. We were guests of SCCA in a single PCA-only run group. That meant limited track time, with only two thirty-minute sessions each day: two practices on Friday; qualifying and Sprint 1 on Saturday; Sprint 2 and Sprint 3 on Sunday. The latter two races would count for National Championship

and West Coast Series points. This also meant a single run group with everything from Cup Cars to SP1s and everything in between. With 50 PCA Club Racers on that short Laguna Seca circuit, which included 14 SPBs, setting quick lap times in each session would be critical to a successful weekend.

Friday evening, things were looking pretty good for me. I was tasting Adobe Road Wine at the reception hosted by Golden Gate Region DE sponsor, *The Racers Group*. Better still, I was third fastest of the SPBs in Practice 2 and would start Saturday's qualifying immediately behind the speedy Nathan Johnson. If I could stay on his bumper for the first hot lap, I felt I had a reasonable shot at a good starting position for Sprint 1. Unfortunately,

Nathan quickly pulled away, so I was left to post a time on my own. I fell woefully short, finishing the session with the slowest qualifying time in class. This was disappointing, but on the bright side, starting from the back would give me a good opportunity to practice some racecraft in Sprint 1.

Sprint 1 was full of fun, nose-to-tail racing in a six-pack of SPBs. At the front of the field, Heath Spencer and Nathan Johnson had a hard-fought battle for first, until Nathan retired after a dramatic 360-degree spin in turn 6.

Heath Spencer, Chris Hamilton and Trygve Isaacson took the podium spots. I managed to move up to eighth, but with only the 10th fastest lap, I would start Sprint 2 near the back again. My buddies tried to lift

my spirits and helped me check the toe settings and the ECU for codes after the race. But that just confirmed what I suspected: there was nothing wrong with the car and, as my friend Heath Spencer likes to remind me, I need to *just drive faster*.

The first 2/3rds of Sprint 2 was wild, with lots of door-to-door action and many multi-turn passes and re-passes between Tim Smith, Michael Tsang, David Leyvas, Trygve Isaacson, Pucky Loucks, Chuck Krause, rookie Andrea Correll and myself. In lap 11, Pucky lost his battle with dynamic rear toe due to a loose toe arm nut, grazing the tire barrier in turn 5, and a Cup car got stuck in the gravel at the exit of turn 11, leading to a three-lap full course yellow.

I couldn't take advantage of the re-start and finished 9th of 14 SPBs. Heath Spencer drove around a damaged rear toe arm heim joint and capitalized on a late-race Nathan Johnson off in turn 5 to claim the top spot, while Chris Hamilton finished third. I was establishing a pattern; at 13th fastest, I'd be starting near the back yet again.

Sprint 3 was a less exciting version of Sprint 2, with a lot of action early in the race. Even with the benefit of

a late-race two-lap full course yellow when Pucky found the beach at the top of the Corkscrew, I wasn't able to pull myself up from the back of the field. At the front, Nathan Johnson matched Heath Spencer's spirited driving, beating him by 17 hundredths of a second, followed by Tim Smith in 3rd. The race re-start was controversial. Several racers advancing between turns 10 and 11 when their spotters announced the green flag and the turn 11 flagger was slow to drop the standing yellow. After reviewing video, the steward determined there had been no passing under yellow, because the turn 10 flagger had dropped the yellow flag and all passing had been completed prior to the drivers reaching the turn 11 flagger (who was in the process of dropping the flag).

And so ended the second of two fun, action-packed PCA Club Racing weekends, though with wildly different outcomes. While my performance at Laguna Seca was disappointing and the results weren't nearly as good as at Buttonwillow, I've been reviewing data and video and have some ideas for how I can *just drive faster* at our next club race at Sears Point. 🏁



opposite page: competitors and friends, Tim Smith and Heath Spencer help Doug with a late night gear box swap last March at Thunderhill. PCA at its best!



above: we managed to get most of the SPB cars and drivers together for this shot

left: Doug Boccignone



upper right: Tim Smith

left: Heath Spencer

right: Jeff Shulem



left: Charles Krause

right: Chris Hamilton





HPDE Insurance you can count on



PCA members receive discounted rates from the largest and most experienced source for HPDE and Off-Track Insurance

LOCKTONMOTORSPORTS.COM

Facebook.com/LocktonMotorsports

Program administered by Lockton Affinity, LLC
D/B/A Lockton Affinity Insurance Brokers, LLC | California License #0795478

DOES YOUR LIFE INSURER CHARGE YOU EXTRA FOR RACING?

MARC H. MILLER CLU®, ChFC®, RIA®

OVER 30 YEARS OF EXPERIENCE INSURING OUR PEERS

LIFE & DISABILITY INSURANCE FOR CLUB RACERS & ENTHUSIASTS



120 BROADWAY, 37TH FLOOR | NEW YORK, NY 10271
212.701.7979 MMILLER@STRATEGIESFORWEALTH.COM

Registered Representative and Financial Advisor of Park Avenue Securities LLC (PAS), OSJ: 120 Broadway, 37th Floor New York, NY 10271. phone: 212.701.7900. Securities products and advisory services offered through PAS, member FINRA, SIPC. Financial Representative of The Guardian Life Insurance Company of America® (Guardian), New York, NY. PAS is an indirect, wholly-owned subsidiary of Guardian. Strategies for Wealth is not an affiliate or subsidiary of PAS or Guardian. Guardian, its subsidiaries, agents, and employees do not provide tax, legal, or accounting advice. Consult your tax, legal, or accounting professional regarding your individual situation. 2017-37627 Exp. 3/19



ENTERING AUTOCLUB SPEEDWAY A DIFFERENT WORLD

A FATHER / DAUGHTER TEAM WITH SPEC BOXSTERS

STORY BY ERIN VOGEL

Heading into Fontana's Auto Club Speedway is like entering a different world entirely from the one that exists outside the gates on Cherry Avenue. I'm not talking about the physical differences, but rather the palpable change in energy. Twenty years of cheering fans, tire rubber, motor oil, high-octane fuel, and laser focus have seeped into the DNA of the place and breathed life into the still surfaces of tarmac, cinder block, and steel.

The stresses of work and traffic instantly dissipate as the atmosphere of quiet anticipation embraces me, the

incredible feeling of this pervasive stillness creating a perfect foil for the fleeting moments of rage in store. Stepping out of my pickup truck, snatches of sound drift toward me on the breeze – the melodic hum of hydraulic lifts, the heart-palpitating rumble of Porsche motors, and the staccato snap of flags thrashing in the breeze – a perfect soundtrack to the start of this 2017 Festival of Speed.

Friday bloomed bright and hot, and the consensus was that the track should be approached with a healthy sense of caution throughout the weekend. It was the first truly warm

weather of the season and the sun was like a Glen Ivy aesthetician, bringing up all the oil and grease that had permeated the surface of the track over the course of the winter. Precision would be even more valued on a slick track, where small mistakes would be magnified by less-than-ideal grip.

In the Friday practice sessions, I had the valuable opportunity to drive with a number of racers I'd never driven or competed with before. Particularly, the chance to chase the drivers of the 944 Cup cars through the playground was extremely fun and educational. Those drivers know

how to corner without giving up one iota of momentum, so for me to tuck in behind them gave me the courage to attack many areas of the track harder than I would have on my own. Of even more notable value were the practice starts and practice race in the final session on Friday, where we all had a glimpse of our competition for the weekend – and where I discovered that not only were the 944 pilots fantastic momentum drivers, but also wicked at the start and definitely worth watching out for!

Saturday announced itself as another scorcher, and I was glad to get qualifying out of the way early in the day. Blue Race 1 was everything I'd hoped it would be, and so much more: more confusing, more overwhelming, and still a lot more fun!

My previous racing experience never provided such large fields, and trying to keep track of not just one or two or three, but what must have been 10 or 15 other cars, was thrilling. And honestly it was a challenge that was a little bit beyond me at that moment! After losing positions to a number of cars in my class, I spent most of the race trying to catch the rest of the Spec Boxster pack, and ended up running most of the race near a couple of GT4 cars, including Brent Gokbudak. It was very interesting to see the difference in the ability of the Boxster versus the 911 in various places on the track, and all I just kept thinking what a pleasure it was to be out there racing with such talented drivers.

Sunday dawned cooler and with a touch of overcast, and the improved weather set the perfect tone for the final day of a great weekend. Sunday's races were perhaps my favorite of the weekend, as I got to spend a good part of both competing with my dad – and in true family spirit, we really do love to race against each other.

We spend so much of our free time discussing driving and race craft, so racing together is comfortable on a level that is more difficult to achieve with drivers that don't share that

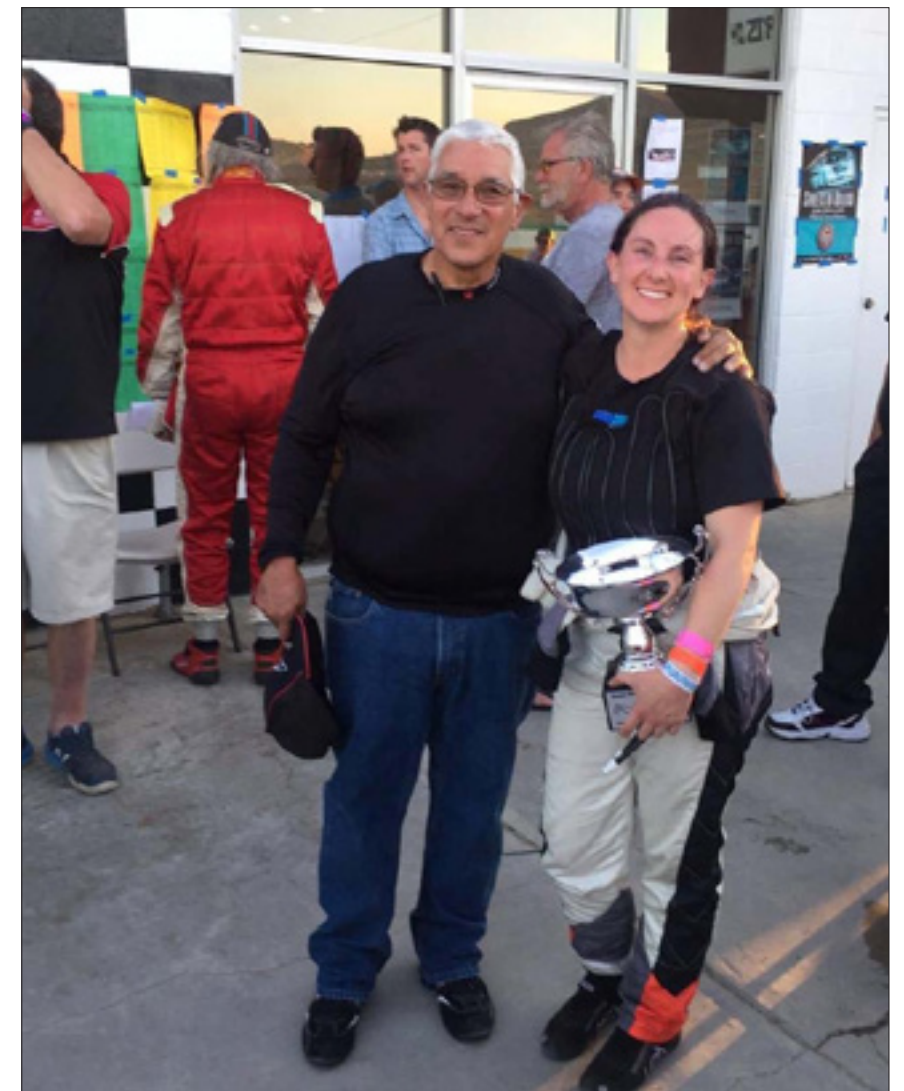

kind of familiarity. Because we often know what the other is thinking and because of the level of innate respect and trust that we possess and have developed, we push each other to be better in the heat of the moment. No matter what order we finish in there is nothing to diminish the fun of that kind of competition, nor the excitement we have for each other's successes!

Perhaps my favorite part of the weekend, and what made it truly special as far as race weekends go, was the unusual atmosphere of vendor row. Throughout the weekend I ran into a number of people I've met in other areas of the auto world, drawn by the shared love of Porsches and driving. Many families wandered through the campground

where we were parked, and my little orange car was like a California poppy attracting bees in springtime. The kids loved to look at and touch the car, asking all kinds of questions about the sponsor stickers, the bright yellow brake calipers, and why the steering wheel was on the roof!

Their enthusiasm was intoxicating, and by the end of Sunday I was on high from both the great competition and the exciting social aspects of the weekend. The organizers from PCA National and PCA Zone 8 receive my hearty congratulations for an extremely well-run and thoroughly enjoyable event. Many thanks to everyone who helped put on this truly first-class event – one which I look forward to repeating in years to come! ❑

Vintage Racing

I am Fred Pfeiffer, newly appointed PCA Club Racing Vintage Coordinator. I am a Potomac member and have just finished six years as their Race Chair.

I race a 914-6 in VRG and now PCA Vintage racing.

Having staged the inaugural Vintage Group race at Potomac's Silver Anniversary event this past September, PCA Club Racing is committed to adding more cars and drivers as well as more events across the country.

If you own or drive a '83 or older AIRCOOLED Porsche race car and would like to race it, we have the place for you. If you have a four-cylinder car like a 356, 912 or 914 that struggles in our usual classes, we have the place for you. If you have an older car that you have swapped engines in and puts you in a race class that is not favorable, we have the place for you. If you are currently racing your 911 or 914 against newer cars with twice your horsepower, we have the place for you.

Talk to the twenty drivers that made up our first race group and see how excited they are about Vintage racing with PCA. You will find that they had more seat time, in a better format and felt more competitive than in many years.

If you are a region race chair and want to add more entries and spark more interest in your event, we have an answer for you as well. Our desire is to have four races on the Vintage schedule this year. Ask what we are all about.

To learn more please contact me at: fpfeiffer@atlanticbb.net or call me at: 301.707.9472



Upcoming Events

July 14
Riesentoter Stuttgart Challenge
Monticello Motor Club

September 22
Potomac Club Race
Summit Point Motorsports Park

October 13
Pittsburgh International
Pittsburgh Int Race Complex

November 11
Motorsport Ranch



Apex Performance

Premier Racing Outfitters



NEW! All helmets include integrated electronics and patented helmet release system.



Durable Trackside Gear Bags



It's the most effective heat prevention system.

Full systems, replacement parts & accessories available



Cool-a-Clava
Helmet Cooling Insert



Street & track pads for your Porsche

Three compounds:
DS2500, DS1.11,
DSUNO
Long-lasting,
Easy on discs,
No judder
or vibration.



ALSO AVAILABLE!



Receive a **FREE** fleece lined helmet bag with every SA2015 helmet purchase!



Apex Performance

Premier Racing Outfitters

Visit us trackside, new showroom or online at www.apexperformance.net

Visit us on Facebook to view our track schedule

Orders 866-505-2739
Tech 843-299-0997

Ask for your PCA discount! (available on most items)





From the Chair

VICKI EARNSHAW • PCA CLUB RACING CHAIR

HELP US INFORM OTHERS OF THE VINTAGE SERIES

I have had the chance to enjoy several of our 2017 events as a steward and visiting others. This has been a great opportunity to see what is working for us and listen to your recommendations. These visits also have given me the chance to observe the processes we are implementing to keep the racing field compliant with our rules. One of our 2017 goals is to enhance the expertise of our scrutineers and data-software advisors to help with this goal.

The use of this scrut power has allowed us to find cars running in incorrect classes. In most situations, we have been able to reclass the car. It may appear we are out to find and penalize illegal cars but, seriously, the mantra of the scrutineer's is "How can we get them back on track?"

We want to have the opportunity to listen to you and develop your racing club. At a recent event a member from another organization asked why they should race with PCA. The answer I gave is: *we are accountable.*

You must race within our rules. And, as a racer, if you damage another car and are at fault, you will be assessed a 13 penalty. You do not get a free pass if you are a steward, scrut or donate your valuable time as a volunteer. The rules are the same for all.

The required in-car video has assisted in the accurate assessment of the situation when an impact has occurred. This year we have observed more contact on the straights. We are fully aware of the passing rule that the

passing car has a responsibility for the clean pass. But we also recognize that the car being passed must be aware and accountable. Sometimes this pass is a faster car but, in an incident at Sebring, it was cars in similar classes. A driver setting up a pass will decide on a line from the information provided by the driver ahead by how he places his car. An unexpected abrupt move can result in contact to the passing car. Both the drivers need to share this accountability. David Murry and Bryan Henderson's columns in this CRN review this situation.

To help with everyone's safety, consider installing a rain light. If you do not have running lights, *rain lights* can be installed. This is a tail-light assembly with a flashing light that has a superior effect on grabbing a driver's attention. There are many assemblies available on the web

The PCA Vintage group has four races on the 2017 schedule. We want to welcome 1982 and older Porsches to race with PCA. The vintage group runs in their own run group and has four simple classes. The PCA Club Racing website has information about rules and contact information. I am asking you to help us inform others of the Vintage series. We are racing at Monticello, Summit Point, Pitt Race track and Motorsports Ranch this season.

We are very excited to be launching a new PCA Racing website this summer.

The new website is in the final development stages. Our desire is to have a race website which will be easy to maneuver, easy to find current and updated rules, and easy to get race results. I want to acknowledge the hours of work on this project from David Anderson, Bryan Henderson, Bill Miller and Agency eightysix. On this *PCAClubRacing.org* site you will have information about the West Coast Series, 944 Cup Series, Pirelli Triple Trofeo, and GT4 Clubsport. There will be a page about sponsors and contingencies and current pictures and videos, a page of upcoming events and the ability to register from the event page. We are looking forward to this launch.

A reminder that all paperwork submitted to the Club Racing office (applications or license or medical paperwork renewal) must be fully completed, properly signed and dated. In the case of the medical paperwork, all three pages must be submitted and signed by both the racer and the doctor. By our rules, some medical paperwork must be submitted to the Medical Committee for review and sometimes additional information is needed. We appreciate your cooperation and timely response to any requests. The Medical Committee, as well as the entire PCA Club Racing Staff, is committed to maintaining the high standards that make PCA Club Racing the best and the safest racing program.

Enjoy your 2017 PCA race season
Vicki 🏁

Out Of The Box... Into The Winner's Circle

INTRODUCING...

331 AND 332

ENDURANCE COMPOUNDS



ALEGRA
MOTORSPORTS

- CarbonMetallic® Race Pads
- ZERO FAILURES™ V3 Discs
- ZERO DRAG™ Calipers
- RH665 Racing Brake Fluid



1st In GTD
2017 Rolex 24hr
Daytona International Speedway





View From the Tower

BRYAN HENDERSEN • CHIEF STEWARD

THE BELIEF THAT THE RULE SAYS THE OVERTAKING CAR IS RESPONSIBLE FOR COMPLETING A CLEAN PASS ABSOLVES THE CAR BEING PASSED NO MATTER WHAT IS A MISCONCEPTION

We continue to have incidents of a type that is not historically common but have showed up over the last year as a significant percentage of the total number of incidents. These incidents are ones that occur on straights where the car being passed is at fault.

I have mentioned this in my last two columns. We are going to try something a bit different. I will write about incidents using the facts rather than general descriptions. I will not mention names, etc. that will identify the drivers involved. Going forward we may be asking for permission from drivers involved to give even more detail. The incidents I will discuss today are very similar and include a common theme of misunderstanding our passing rules.

Incident 1:

In this incident, Car A was following Car B, preparing to lap him well into the enduro. Car B was following two other cars that he was about to lap. Car A would be two laps up on the two cars that Car B was going to pass. The two cars being passed by both Car A and Car B were on the right edge of the track. Car A, who was the overall leader,

followed Car B. Both A and B were in the left center of the track. As Car A approached Car B with significant overtaking speed, he lifted (since the cars ahead did not leave a clear place to pass). Just as Car A lifted off the throttle, Car B moved to the right opening the left edge of the track for a pass. Car A went back to the gas and moved to the left edge for the pass.

The pass would occur as Car B was passing the other two cars making it three wide. The 36 foot wide track was narrowing to 30 feet. The two uninvolved cars were taking up about 6 feet on the right edge of the track. Car A was taking up about 6 feet on the left edge of the track. This left about 18 feet in the center for Car B. Car A had almost cleared Car B when contact occurred with the left front of Car B and the right rear of Car A, the passing car. When contact occurred there was about 12 feet of open space between Car B and the two cars on the right edge. Obviously there was no room between Car B and the car passing him.

The driver of Car B believed that the overtaking car had the responsibility to complete a clean pass and did not do that. Car A believed that

since Car B moved to the right he was aware of him and giving him passing room. You do communicate with the other cars around you by how you place your car.

The steward's decision was based on the video evidence that Car A had done everything correctly to make a clean pass. Car A was just barely on the track on the left edge. The steward believed that there was plenty of room to Car B's right and that Car B failed to leave racing room to a car that was clearly passing him on the left and Car B was therefore at fault. Video indicated that Car B was on a line that would have put him on the left edge of the track a couple hundred feet after the contact. Video indicated that Car B made no effort to avoid Car A which indicated that he likely did not know Car A was there.

The incident decision was appealed. The steward's decision was upheld in the appeal process.

Incident 2:

In this incident, Car A was following slower cars in the enduro, preparing to lap them as they exited a fast left and continued down a straight leading to a slower right turn. Car B had two cars between him and Car A

as he exited the fast left. The two cars behind Car B were faster and Car B moved to the center to let them pass on the right. Car A was faster than all three of the other cars and moved left to pass all three on the left on the straight. The two cars that were on the right did not attempt to pass Car B. Video indicates about mid-way down the straight Car B, who was in the center of the track, made a definite move to the left apparently to set up for the turn in to the right hander. At that time, Car A was passing Car B on the left. The pass was almost complete when contact occurred with the left front of Car B and the right rear of Car A.

The driver of Car B believed that the overtaking car had a responsibility to complete a clean pass and that he did not do that. Therefore, Car B believed that Car A was at fault. The driver of Car B also believed that Car A was going so fast that he could not have made the right-hand corner. The driver of Car A believed that the left lane was open and that Car B's staying in the center indicated he

knew he was passing on the left.

The steward found Car B at fault. The steward's decision was based on the video evidence that the driver of Car A had done everything correctly to make a clean pass. The steward believed the incident was caused by Car B moving to the left as he was being passed on the left. Video indicated that he likely did not know Car A was there since he turned into him as he was going by. The steward also believed that Car A would have slowed enough to make the right hander after completing the pass.

There have been a couple more incidents following this same pattern. The belief that the rule says the overtaking car is responsible for completing a clean pass absolves the car being passed no matter what is a misconception. That thought does not take into account that drivers must leave racing room. We must apply common sense here.

But for the actions of Driver B in both of these incidents, contact would not have occurred. In both situations, Driver A set up what

would have been a safe, clean pass if Driver B had left racing room as he should have.

You must be aware when changing lanes on a straight. As we tell rookies, you are responsible to know what is going on three hundred sixty degrees around you at all times.

The new rule requiring operating video in all cars has made resolving incidents much easier, quicker and more accurate. All drivers should make sure their video is always operational.

We have also had a couple of incidents involving a spin. The principle involved is that when a car spins or otherwise loses control but is still moving, if contact occurs when drivers try to pass, the driver losing control is normally at fault. We can't find someone at fault because the evasive action they took in what is an emergency situation did not work. In most of these situations, but for the loss of control, the incident would not have happened.

Go Fast — Be Safe — Bryan. 🏁

Utah Motorsports



Campus Sept 15-17

CLUB RACE AND HIGH PERFORMANCE DRIVERS EDUCATION (HPDE)

The UT Motorsports Campus is 4.5 miles long with 23 turns, elevation changes and twelve straights. UMC includes a paved paddock with amenities, garages, covered trackside facilities and is only 30 minutes from downtown Salt Lake City.

FRI - Test & Tune and HPDE

SAT - Sprint Race and HPDE

SUN - Super Sprint Race (40 min), 1 hour Enduro Race and HPDE



Photo by Eric Schramm

Region, Event & Hotel Info.
<http://www.IRPCA.org>

Race Registration open 07/31
<http://register.pca.org>

HPDE Registration open 07/31
<http://www.motorsportreg.com>

Race Chair - Ed Mineau
emineau@comcast.net
801 597 3037

HPDE Chair - Greg Troester
greg.t@comcast.net
801 633 1928

Registrar - Devinder Singh
mdufford@mindspring.com
801 232 6507



TOTAL TRACK TIME: 6+ HOURS!





RACECRAFT 1 AN INTRODUCTION

WHY DON'T MORE DE GUYS GO CLUB RACING?

STORY BY MIKE (MUGS) MULLIGAN, PCA NATIONAL CHIEF SCRUTINEER

It's a chess game at 100mph...

As I write this, I have just returned to (sorta) sunny Southern California from the Clash at Watkins Glen, and must admit that I am feeling rather seriously jet-lagged. Modern air transport is really an incredible thing when you think about it, but it does have some interesting side effects. Aside from the normal stuff (like waking up wondering where you are and realizing you've been out cold at work for twenty minutes) it seems to me that we tend to lose a realistic concept of distance, at least temporarily. I mean, you just sit in

an aluminum tube for a few hours and you're there. Can't be THAT far... I start thinking "Man, I need to come out and race here".

Then, of course, I recall that if I lived any farther from the Glen getting there would involve sea travel.

Still, hope springs eternal, and I will never give up on the idea of running out there. After all, the only thing better than being with you guys at a race would be being with you guys on track...

Sitting on a plane for hours does give one plenty of time to contemplate the various issues that trouble mankind, but on the way home

from the Glen matters of faith, philosophy, art, music and politics took a back seat in my mind to a truly baffling question; why are folks not as interested in automotive performance as we are? (I know... Cut me some slack, I was tired.)

When I ask that question I understand that a big part of our population is oblivious to cars in general, and I'm not talking about that guy who says things like "I have no idea why anyone would care how fast a car goes from zero to 60 miles per hour..." There is no hope for that guy; he's doomed to a life of golf.

The guys I was thinking about

are the ones who like cars, sports cars even, and seem to like a *spirited* drive through the hills, but have no inclination to go to the track. I think that in a lot of cases they don't really see the difference between driving through the hills (or to the golf course) and driving on the track. I mean, it's just the same only you are going faster, right? To those of us who have been doing this for a while, that would be a ridiculous statement. Driving at the limit is so different than street driving I'm surprised they use the same word for both activities. But, without the experience of near (or over) the limit driving, they have no frame of reference.

Thinking further along those same lines led me to wonder why more of our friends who are faithful DE participants don't go Club Racing. I think it may again be that they have no frame of reference. A lot of these guys have been on the track for years and are driving some pretty fast hardware, but have no interest in going racing because they think it is pretty much the same as what they are already doing. I mean, it's just the same only you can pass anywhere, right? Again, to those of us who have been racing for a while, that statement indicates a misunderstanding of the fundamental difference between DE and racing, but without a frame of reference it's a difficult thing to grasp.

It is entirely possible that many of us who have been racing for years still haven't entirely grasped the difference!

Stick with me, here.

When we start track driving the first thing we are generally taught is what a *line* is, and about things like turn-in points, apexes, brake zones, apexes, track out points, apexes, apexes (Wow, these folks are REALLY into apexes!) and... tire pressures. As we progress we learn more about car control, handling balance, smooth braking and steering inputs and expanding our limits. During this time we are learning to drive by



feel, interpreting what the tires are doing by the feedback we receive through the seat, wheel and pedals. As we become better at feeling what the car is telling us we can push the limits up a bit.

At this point we're completely hooked on this stuff and we begin to hone the skills that we have developed. We are concentrating on the subtleties of line and car control in an effort to lower our lap times, and maybe more importantly, catch ol' Fred up there (nothing like finally getting that point-by!). The mantra is that a good line and good driving skills produce fast laps. We are having a ball driving with our friends, chasing each other around the track and gauging our improvements in tenths of a second.

And this is where the disconnect occurs

The typical thinking goes like this; "If we were racing I wouldn't have had to wait for a point by so I would have passed him on the previous straight (or corner, wherever...) because I was faster. But, to go racing I would have to install a (insert piece of safety equipment here) and pay more for my entry, so I don't really see the point. I'm pretty happy dong D.E.s".

And that brings us back to that fundamental difference between DE and racing; in a race Fred doesn't want you pass him, he doesn't have to let you pass him, and he is allowed, within

reason, to do what he can to keep you from passing him. A race is a battle of wills. You want to pass Fred, he wants you to stay behind him. You have to figure out a way to get past him, and he has to figure out how to keep you in his mirrors. It isn't necessarily a speed contest, it is a chess game played out at 100 miles per hour and the one who can better analyze the strengths and weaknesses of his opponent will have the upper hand.

In a DE or time trial, our opponents are inanimate objects, the track itself and the clock that are both static, known quantities. In a race your opponent is another human being, often wily and unpredictable, who is trying to beat you in a game that is played at full speed over that same piece of asphalt that you were struggling with in the DE. It is the participation in this one-on-one contest that appeals to so many of us. It is also very hard to understand if you have never had the experience.

If you are a long time DE driver that has never tried wheel-to-wheel racing, you owe it to yourself to give it a go. The direct competition aspect of racing is the thing that creates the unmistakable *rookie grin* that is so apparent in the paddock after a race (By the way, half of the folks sporting the *rookie grin* at the end of a session have been doing this for decades). And, oddly enough, it will also improve your track awareness and car control.

If our success in competition is going to be based on who can devote the most of their attention to the task at hand (beating the other guy) then we need to make the things that were once foremost in our minds as DE drivers, track awareness and car control, second nature in a race situation. Racing encourages this shift in our attention because it provides us with immediate feedback about our driving. If you are closer to the guys ahead of you coming out of a corner, you were quicker, if you lost ground you need to try something different. No waiting to see a lap time, no wondering where you were faster or slower over that lap, just instant awareness about whether you are getting the job done or not. And remember that that job has changed; you aren't chasing a lap time any more; you are chasing Fred. It's no longer just business; it's personal!

This immediate feedback can also tell us a lot about Fred if we are paying attention. He may be much slower through a particular corner and faster through another, or his car may not be working as well as yours in certain places around the track. This is the type of info we can use to our advantage when it comes time to put a pass on ol' Fred if we have the ability to take it all in, process it and then exploit it when the time comes. This type of *tactical attention* is part of something that has come to be known as *racecraft*, and it speaks to the essence of motor racing.

The term racecraft is kind of like the word "science" in that it encompasses so many different aspects that it is difficult to know where to begin. It is certainly too involved to cover, or even begin a meaningful discussion, in one magazine article, but I think it is a topic worth looking at in a little more depth. Especially since I feel it is the most important thing that we never talk about.

A discussion of racecraft could fill a book and has; several times as a matter of fact. But it seems to me that they usually focus on things like car set up, slipstreaming/drafting,

choosing reference points on the track, where we are looking, what we are seeing on the track and things that are very similar to the things we've already read in the books about track driving in the first place. Others like to focus on the physical aspect, diet, workouts for better fitness and the like.

These are all valid aspects of the racer's craft, but the mental aspect of that one-on-one competition has always been fascinating to me and, as I said above, it is a subject that I feel has not been given the attention it deserves, at least at our level.

Improving the way you think while in the car has the potential to up your personal racing game, and it may be the only thing in racing that is genuinely free! Unfortunately for most of our track-bound lives we have been concentrating on going faster so that we can catch the other guy, but not on what we plan to do once we get behind him. Someone once said that the pass begins a lap before it actually happens. Taking time to size up the competition by being more observant, taking in all of the information that is available to us (or as much as we can), making a plan based on that information and executing the plan. This is real racecraft and it doesn't happen automatically for most of us. We need to make a conscious effort to be proactive rather than reactive.

Just how to begin to change the way we think in the car is a tough subject. Like I said, there are so many aspects to racecraft that it is difficult to know where to begin the discussion. I think that refining our ability to observe what is going on around us is as good a place as any, so we'll pick up there next time. Until then, an observation and a story:

Your brain is the most powerful thing in your race car and is capable of processing much more info than we are often consciously aware of. (Okay, a whole bunch of you just thought of someone in particular and said "It certainly is not the most powerful thing in HIS race car..." Stop it. Stick with me here...). I

have an example from my own experience, and I only remember it for one reason.

I was in a race at Buttonwillow raceway near Bakersfield. In the fastest sweeper on the track I noticed a bird flitting about out in the runoff area and thought "what was that crazy bird doing?" At the time I was catching a 911 and was watching the way the car was handling, the way he was driving it, where he was quick and where he wasn't and formulating a plan for when I got into position to make the pass. All the while the adjustment of line, adjusting for little slips and slides and other aspects of controlling the car was happening automatically. Noticing the bird didn't affect anything I was doing, my concentration remained fully on the task at hand, namely running down the 911 and formulating a passing plan, but it did cement the moment in my mind. I thought it was amazing that amongst all of the things that were going on at that instant, both consciously and unconsciously, my brain was still able to see, and take note of, that stupid bird without affecting anything else.

Oh, and I did pass the 911. (I know you were wondering...)

I'm not telling that story to make it sound like I'm something special. On the contrary, we can all do this sort of thing. It is what they call *being in the zone* and we have all been there at one time or another. I think that this may be a good beginning definition of racecraft; *being in the zone on purpose rather than just waiting for it to happen*.

As I've said several times now, this is a huge subject and it would be fun and informative to have input from many sources. To that end, if you have any comments, stories or questions on the subject of racecraft I hope you'll add to the discussion by passing them along to me at mike@mulliganracing.com.

I hope this is going to be a topic that is interesting and helpful, please let me know what you think.

See you at the races! 🏁

...a bad day

a good day...

THAT'S RACING.

- FOR ALL OF YOUR PORSCHE AUTOBODY, PAINT & FABRICATION NEEDS
- WE WORK WITH ALL INSURANCE COMPANIES
- PORSCHE APPROVED COLLISION CENTER
 - REPAIRING & RESTORING PORSCHEs FOR 35 YEARS
 - RECOMMENDED BY PORSCHE MOTORSPORTS NORTH AMERICA
 - SPECIAL CONSIDERATION GIVEN TO RACE CARS
- WE ARE A FAMILY-OWNED & OPERATED BUSINESS FOR 35 YEARS
 - CERTIFIED ALUMINUM BODY & CHASSIS REPAIRS WITH STATE-OF-THE ART EQUIPMENT
 - **BODYMOTION... IS YOUR ONE-STOP SHOP**





MY FIRST RACE AS A ROOKIE

JUST HOW MUCH FUN CAN YOU HAVE DRIVING YOUR FIRST PCA CLUB RACE?

STORY BY BRUCE WING; PHOTO BY TED LIGHTHIZER

There I was, Thursday, in the pits at AutoClub Speedway for the California Festival of Speed. Bryan Henderson, the PCA National Stewart, led the Rookie Driver's meeting sharing words of encouragement and stressing the importance of safety.

PCAs passing rules are a little different than what I was used to from the POC Racers Clinic, but other than that, everything else was about the same. I was reminded that when I am the overtaking car, it is my responsibility to execute a clean pass. Because this was my Rookie debut, I wanted to avoid any sort of contact during the weekend that could hinder obtaining my full racing license.

Porsche Owners Club President Ron Palmer reminded me that the

most important thing was to be smooth and have fun. He also assured me that I would receive POC credit for the three sprint races that I would run this weekend. Having driven 105 laps on this track configuration during the past four years, I felt I knew the track well enough and was looking forward to the weekend.

Friday's warm-up went well. Tire pressures were set perfectly. I found myself starting behind a car that was faster than me. I liked the line he was driving and followed him for about five laps. To my surprise, he made me faster than I have ever driven Fontana. Looking at my data, I gained three seconds from my fastest lap time ever.

I felt ready for Saturday's first race,

and arrived really early to the grid. I was P10 in the Orange Group. I remember a fellow racer telling me that all I had to do was watch the flagman at the start and make sure not to hit the car in front. As the pack moved toward the final stretch, all I could hear were the screaming Boxster Spec cars all around me. The grid was tight and I was tucked in behind another GT car.

The green flag dropped and before I could blink I was passed by 10 cars before Turn 1. I thought to myself, "OK, it's on!" I moved down to the inside and held my line around NASCAR 2. As we approached Turn 3 (a sharp left turn after hard braking coming off the roval), there were 20+ cars packed into that single turn. It

looked like a wall of cars stopped directly in front of me. I pounded on the brakes to keep from pushing the Boxsters off the track, kept the inside line and made it through without problems. I thought to myself, "Great, I made it through the worst part!"

For the next sequence, Turns 5-6, I missed my shift out of Turn 4 and two more Boxsters passed me going into 5 (one on the inside and one outside). Out of 5 I had a jump on the outside car and passed a Boxster going into the kink. I went too wide into the playground and learned the line I was using was way too bumpy for my car, causing me to slide out too early towards the flag station before the front straight. On the roval I was full throttle and stayed in lane 3 where I was able to pass a few cars before Turn 3. After 15 laps I was out of breath, probably because of I forgot to breathe in several places. After parking the car and checking tires and brakes, I went to see how I finished. The times were posted in the meeting room and at first I could not believe what I read: I had finished 7th after starting P10! I was stoked that I had moved up.

During the race I had the opportunity to drive alongside a *rabbit* by the name of Garrett Guess in his J class 996. I had so much fun that I had to find him in the pits to thank him for driving so well and giving me some room to explore the track. Garrett's car was so fast on the straights that he would disappear until Turn 3, then we would trade places and stay close. In Sprint 1 I even passed Paul Young who's driving skills I admire and respect. I guess Paul just gave me the pass to make me feel good. Feeling good about my first race, I was really looking forward to Sprints 2 and 3 on Sunday.

8:30 practice. When doing my pre race check I discovered that I had a flat left rear tire. Despite adding air, the sound from the back of the rim told me the tire was done. I remembered when coming out of Turn 4 I ran off the end of the gator and found that big hole. I had no idea that I

finished Sprint 1 with a fast leaking LR tire. Sure enough, the inside LR rim was badly bent. I changed rear wheels, checked the pressure and there was that hissing again. I had just bought these new wheels and the vendor hadn't tightened the valve stems! I got everything taken care of and arriving to grid little a late.

I told myself that I would not get smoked at the start again. I was P9 and had the inside line at the start. I gave myself more room in front and power braked the car to get the engine into the power band.

As the green flag dropped, I stepped out to the inside and stayed down. I was able to move quickly into P4 before Turn 3. I had a good start. As I exited 4, trying not to run off the end of the gator I missed my shift again. In a blink the eye, the pack was on me like glue. We were three wide going into 5-6 when a Boxster passing me on the outside hit another Boxster who was passing me on the inside. The Boxster's passenger door fell off and was directly in front of my car. The door-less Boxster didn't skip a beat and I quickly jumped in behind to avoid running over his door.

The rest of the session went well and knew I was ready for the fun race, Sprint 3.

Since it was a no points fun race, most of the other drivers had packed up and were done. I was early to the grid, but something was really different. The super fast Cup Cars and Dwain Dement's twin turbo beast were going to be out on the track with me. We lined up for the green. Boom! We were off! I could hardly hear myself think behind the screaming Cup Cars (note to self: get some ear plugs!). Around to 3 and again in front of me was a parking lot. I was able to sneak inside and gain a spot or two. On the second lap we were still bunched up. Well, some of us were bunched up while the Cup Cars were gone. As we headed into 3, I saw a Boxster in my mirror on my inside diving in deep to out-brake me into 3. I glanced over to see another

911 on my right out-braking me as well. Knowing that I was a Rookie, I did not want to challenge the turn, and gave it up. Thank goodness I did because the Boxster T-boned the 911 right in front of me between 3-4. I drove out wide to avoid being part of the carnage. Then, back on the gas and off I went. For about five laps it felt as though I was the only one on the track, no cars in front or back. As I popped up on the front straight, the starter was holding up one finger indicating the last lap. As I entered Turn 1, I could see two 944s ahead. I carefully thought out how I was going to pass and out-brake them into 3, just as I was passed earlier in the session. Sure enough, I made the pass (well, I thought I did). Going into 3 too hot caused me to over-correct and I found myself on the outside of 3 going into 4. Well, because the 944s don't use their brakes, I caught Isabella Busalacchi coming around me on the outside. I then decided that I would stay inside of 4 and drive over the top of the gator to give her and the other 944 room to pass, if they could. I made the mistake of rolling over the top of the gator and hooked my RF wheel, inducing a quick 360 spin and I ended up pointing in the correct direction. Shifting into first gear, I proceeded towards the checkered flag. What a great event and fun weekend!

Back at the pits I was told the scrutineer was looking for me. I thought I'd hit the 944s and didn't realize it or was afraid I'd caused a problem with my spin. Instead, I found Bryan Henderson, the head man. He wanted to congratulate me on being the Most Improved Rookie of the weekend and gave me a \$100 gift certificate. Phew, all is good and I even won something at CFoS.

Thanks to all the volunteers and staff who participated and helped make this one of the most memorable weekends at Fontana I have ever had. I am looking forward to our next track weekend at Big Willow. Thanks everyone for all the kind words and help at the track. This club is great at motivation! 🏁



**WHERE
DO YOU WANT TO
FINISH?**



MOTON / AST SUSPENSION NORTH AMERICA | 17925 SKY PARK CIRCLE SUITE F IRVINE, CA 92614 | 949-502-6243 | INFO@MOTONSUSPENSIONUSA.COM



NANO DRIVE
LOW FRICTION TECHNOLOGY

MORE HORSEPOWER, LESS WEAR

Millers Oils is proud to be a 2017 PCA Club Racing Sponsor.

Award winning Nanodrive engine and gear oils deliver extreme performance.

Added protection to engines and gearbox

Up to 3000 race miles life

Tri-Ester, PAO and NANO-Technology

Superior film strength

80% increase in load bearing



Porsche Club of America San Diego Region presents the

PCA Willow Springs CLUB RACE & Time Trial

Fastest Road in the West

Sept. 30 & Oct 1, 2017

Time Trial Registration opens August 20

Club Race Registration opens August 14

The points races at this Club Race will earn points towards the West Coast PCA Championship Series as well as the PCA National Championship



Dealer inquiries welcome
Performance Racing Oils
Tel: 865-200-4264
info@performanceracingoils.com
PerformanceRacingOils.com
*contact Performance Racing Oils for details.



"Learn more about Millers Oils"



Editorial License

SKIP CARTER • CLUB RACING NEWS EDITOR

It has been an exciting three months since publishing the last issue of Club Racing News. I was able to get to the Watkins Glen event, my first time on that facility. This was the first PCA race I've attended that was 100% club racers — no DE.

The national staff that it takes to put on one of these large club races compared to the rest is pretty amazing. With no break in the tower, it takes two stewards tag teaming, at least two timing techs and the largest group of scruts I've seen.

The quality of all of the local personnel I met was absolutely professional, experienced and tightly run.

The two photos on the right are (top) Bill Miller and Mike Hoke. The bottom photo shows timing techs Simon Pontin and Dave Anderson. The scrut team was headed up by Mike Mulligan.

I don't know what it is about that facility, but after three days I still could not negotiate my way around that place. I guess I'll just have to go back again!

My next new track will be Motorsport. Suesan and I will be in Toronto for a wedding the same weekend, so I have a pass to spend Saturday at the track. I've heard such good things about it, I can't wait. 🏁

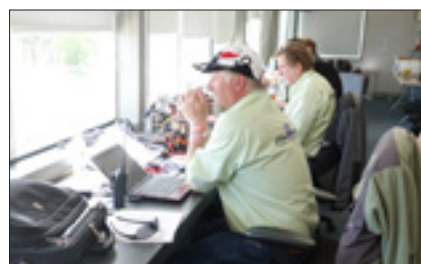
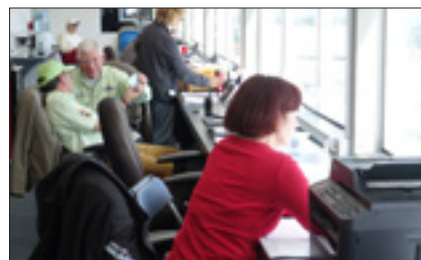

A QUICK GLANCE

SKIP CARTER

Summit Point Vintage Race

Last September I had the pleasure of attending the first ever PCA Vintage Race, part of Potomac region's 2016 Club Race at Summit Point.

Here are just two of the drivers in that group, Paul Behofist and Mike Spraggins. I spoke with many of the

Vintage drivers and, with few exceptions, for most of these drivers it was their first PCA Club Race. They were very happy that PCA has brought vintage racing into the club racing program. The general complaint about most other organizations is how much time you spend waiting to get on the track, compared to PCA

where you get a tremendous amount of track time.

We would like to see a Vintage Race somewhere on the West Coast. There are a ton of cars that would probably love the opportunity. We just need one of our events to make it happen. Anyone interested???



JX2

PERFORMANCE GROUP

IS PROUD TO ANNOUNCE CONTINGENCY FOR ALL NON-SPECIFIED TIRE CLASSES IN PCA CLUB RACING.

GO TO WWW.JX2PG.COM/CONTINGENCY FOR DETAILS.



JX2 Performance Group is proud to offer Pirelli tire sales, service and full team support at select PCA racing events.

Visit JX2pg.com or call 866.325.5426 before your next race.



Official Sponsor





LE MANS — THREE-PEAT

BY SKIP CARTER; PHOTOS COURTESY OF PORSCHE AG

I remember going to Porsche Parades, year after year. Inevitably, during the Porsche banquet, when the representative of the factory gave his speech, in spite of all the great information that we were given, someone(s) in the crowd would always ask... "What About Le Mans?"

Then we got the Porsche Spyder, the LMP2 car, and we all wondered "Why would Porsche build a car designed to come in second?" Did they not remember Peter Schutz's dictum when he was Porsche CEO in the 1980s? "Porsche will not go to a race without a chance to win!"

So the questions keep up: "When are we going to Le Mans?"

Now that we've got three consecutive wins under our belt, I think I can finally *forgive* Porsche for making us wait so long.

Was it worth the wait? You bet! Did we like waiting? No way!

I wondered why we didn't always have factory representation, and this is my best guess. Fielding cars for the WEC championship (let alone just Le Mans) is incredibly expensive. While Porsche is a very profitable

company (relative to its size), it does not have the same money available that much larger companies like BMW and Toyota would. So Porsche (again, just my opinion) sits out several years (which certainly builds up tension and anticipation with us fans), then puts the full factory effort behind it (which doesn't explain the anticlimactic LMP2 effort).

I guess you can't argue with results. Three consecutive Le Mans victories, 19 overall victories... There is just no one who has done it better. So, do we have a 919 in 2018?

The 919 joins the 936, 956 and

962 in the pantheon of Porsche prototypes that can boast three or more overall wins at Le Mans. And, with this record extending 19th over all win, I am sure that we can look forward to several more years of Porsche racing success.

The photo on the right shows the driving team of Earl Bamber, Tino Bernhard and Brendon Hartley on the podium. As I'm sure you all know, at 6:30pm the #2 919 Hybrid had a 65 minutes pitstop changing the electric motor that drives the front axle. At 7:35 the #2 Porsche reentering the race in P54, 19 laps behind the leading Toyota.

The race started with the new lap record setting Toyotas dominating. The #1 Porsche took the lead as the Toyotas fell out. The #1 had the lead by 14 laps when, about 11pm the car lost oil pressure and was not able to get back to the pits. The #2 Porsche had crawled up the list and was in P5 when the #1 car died.

With an hour left, the #2 car caught



and passed the leader, the LMP2 #38 Jackie Chan DC Racing Oreca, who led the race for several hours before finishing second overall.

One other thing to mention, it

was exactly 40 years since Jacky Ickx, Jurgen Barth and Hurley Haywood brought their Porsche 936 from P42 to win the race. Valiant effort Toyota. I'm sure we will see you next year. 🏆



HUBStands PRO
PATENTED

Fully suspension compliant and height adjustable.
Daytona winning ProHUBStands for the most precise, repeatable, wheels free hassle free set ups.

www.HUBStands.com 888.208.8570 info@bbxracing.com

Canada: www.mantissport.ca Europe: www.bg-racing.co.uk



THE DREAM ONCE STOLEN

HOW SOCIAL MEDIA HELPED RECOVER A STOLEN RACECAR

STORY BY PATTI MASCONI, POTOMAC REGION

Many Porsche Club drivers have taken once-pristine Porsches through various stages, from street-mode to full-blown race car (whether the journey is through one car or several). Along the way some jokes about the coveted nameplate are often made, something to the effect of “my Porsche is now lime green (or insert some other bright color), really loud, old, difficult to get in and out of, and it is largely sitting on or in a trailer.”

So who would steal it? And if some thief did so, you would expect that the nabber would not get very far due to immediately causing a brilliantly loud scene, marked with one-foot-tall numbers instead of a license plate and lots of other graphics.

The joke typically comes with a feeling of security. While there have been infrequent news of vandalized steeds at the track or the high-profile report of bright, brand-new Porsches stolen in Europe at a car show, the theft of one’s own race car seems far-fetched. After all, the race car is probably not being parked on the street in a potential robber’s view, particularly when the windows have been removed, and it may have a complex process for even starting it!

The Intermountain Region’s Greg Troester has always known the 944 as a car to track, as his father Darrell (an ex-Class-F racer with 18 GTC3 wins) introduced him to the model alongside his brothers. After participating in Drivers Education for three

years, the next-generation Utah native started racing a 944S in 2012, because he says the momentum car was also “easy to maintain ourselves.” By 2015, Greg had a different chassis donated by Patrick Sloan, had Maa-co paint it, welded in a roll cage and transferred an engine into the body from his previous 944 that was damaged in an incident.

Greg’s story of the inconceivable crime starts with an unusual line, “While out of town, I came down with appendicitis and ended up having surgery in Hawaii.” Meanwhile, back in North Salt Lake, Greg’s car was being stored in a two-car, family trailer at Hugh’s RV park, when the elder Troester learned the 944 had been stolen along with other trailer



break-ins at the facility. Of course, their initial thoughts were how could this be? – You need to get into the trailer, lower the rear door, and line up some ramps, never mind get away and do something with your new, illegal possession.

“Graphics aside, the #518 has no interior and a weld-in cage,” explains Greg, “no headlights, not even turn signals.” His concern was that since nothing in the car was easy to remove and sell for decent money, the scoundrel who took it would just trash a loved belonging he had built from the ground up to compete in SP1.

Dave Derecola, the 944 Cup National Coordinator, assisted Greg with social media efforts to get the news and a picture disseminated regarding the stolen steed. Greg describes the on-line reaction, “I was impressed by the outreach of our motorsports community: I heard from people as far west as shipping ports in California, to the east coast in Maine and Florida – wow!”

One thought rings true: If you steal a race car, you will get noticed eventually. After what seemed an interminable eight days, a Good Samaritan contacted the car owner through Facebook, with a message that simply read: “I found your friend’s car.” This Good Samaritan had trailed the 944 as it was being driven down the street. The thief was

soon arrested and the car was eventually returned to Greg.

So, after some understandable consternation, the thief’s race ended as a good finish for Greg. Damage to Greg’s race car was limited to some cosmetic issues that are easily repaired. “I’ll continue to race, hopefully getting in a relatively full season this year!” he exclaims.

Greg adds, “even if the car was a total loss, I’d still be working hard to find a way back to the track. There’s no way I can leave it behind!”

left: the recovered car
below: Greg’s dad, Darryl Troester
bottom: Greg with previous SP1 car





Cimarron Region Porsche Club of America

Announces the Original and 16th Annual



OKTOBERFAST 2017

October 7-8, 2017



Cimarron Region is proud to host PCA Club Racers at everybody's favorite racetrack, Hallett Motor Racing Circuit. We are excited to be hosting the 944 Cup West National Championship race! We love having all of you here for one of the highlights of the PCA Club Racing season. The friendly atmosphere, the Saturday night dinner under the Oklahoma stars, the exciting competition, Oktoberfast is a "can't miss" event. We've had a wonderful turnout for our Cimarron Region Boxster Challenge for five years running! Come and be part of the fun.

Registration opens Monday, August 21st, 2017 at 9:00 pm CDT at <http://register.pca.org>

Contacts: Race Chair Jon Jones at 918 740-7951 or jonesjon843@gmail.com

Event Registrar Joy Jones at 918 200-4044 or cimarronpca.events@gmail.com



PCA Mardi Gras Cup 2017 Hosted by Mardi Gras & Whiskey Bay Regions September 15 - 17, 2017

NOLA Motorsports Park is located only 14 miles (20 minutes by expressway) from downtown New Orleans. If you would like to extend your stay, secure trailer parking is available before and after the event. On Saturday afternoon before the first race there will be an Air Force "Flyover" at the conclusion of the National Anthem. You don't want to miss this! The weekend will be a combined Club Race & DE and will include the Cayman GT4 Clubsport Series and the 944 Cup Southwest. We will be using the 2.75-mile configuration with the "esses". Go to www.MGPCA.org for more details.



Thursday T&T hosted by the track.
Registration info will be in the email blast.

Friday – Practice Sessions & Fun races
Saturday – Warm up, Qualifying, & 2 Sprints
Sunday – 1.5 Hour Enduros

Solo only DE Sessions all 3 days

HOLINGER AMERICA

Transmission Solutions for Porsche Racing Cars

Holinger's own sequential gearkit conversion made for 911s was adopted by Porsche Motorsport and was the control transmission in every 997 "Cup" racecar they built. Now, the complete range of Holinger PCS spares and upgrades are available directly from Holinger. Why buy an imitation when you can buy the original?

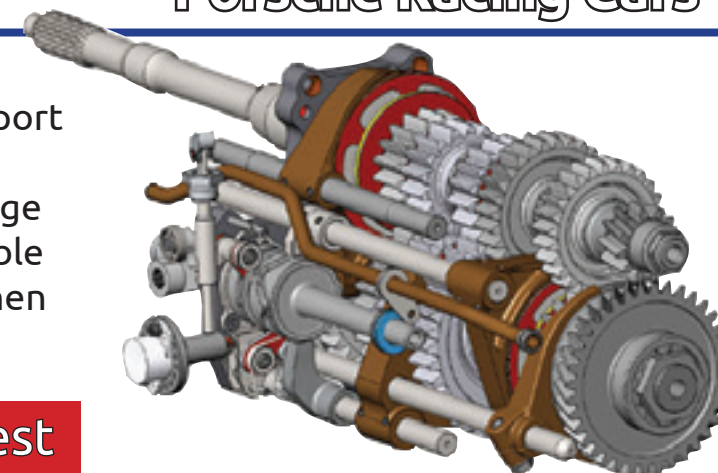

Contact us today to find your closest authorized dealer or expert installer:
info@holingeramerica.com
(949) 362-8750

SPEEDSHIFT
Plug and play
Paddle Shift kit for 997 Cup



HOLINGER Advanced Limited Slip
Available for:
• G50/G96
• 991 Cup

NEW from Holinger for 2017:
• Close Ratio 3-6 gearset for Cayman GT4
• Replacement gear program for 991 Cup

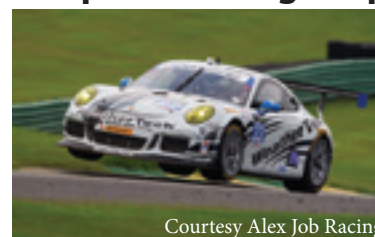

Courtesy Alex Job Racing





ORIGINAL OWNER SPEC BOXSTER PROJECT

19 YEARS AND COUNTING

STORY & PHOTOS BY TRYGVE ISAACSON

Wherein a guy buys a cool car, only to discover there is a whole other world of fun to be had. The car starts as a daily driver, hits the track, gets a few modifications and, eventually, becomes a Spec Boxster (SPB) race car.

Intro

I'd had a mixture of car experiences that led me to purchase the Boxster in 1998. After a few years driving a great but finicky 1972 BMW 2002, utility led me to a used Jeep Cherokee Chief for hauling guitars and synthesizers and amps to rehearsals and gigs. The Jeep let

me down one too many times with expensive unreliability and, no longer needing to cart around all that gear, I felt I should get something brand new, ultra-reliable (and boring). But, after the better part of a decade driving that Honda sedan, I couldn't resist a change. Lots of due diligence on the new crop of two-seater sports cars of the time led me to understand that it was the Boxster that was the real deal, an impeccably balanced mid-engine chassis and (for the time) a good solid punch of Porsche flat-six power. I took delivery of my Arena Red 986 in early 1998.

Early gatherings, First track day

The cars were so new and, initially, so rare, that informal gatherings and drives were arranged. Newfangled "web forums" came on-line to solve problems and to disseminate wisdom and enthusiasm.

At one of these gatherings in late 1998 that someone mentioned the SCCA "Street School" at Thunderhill Raceway. I had no idea such a thing existed; take your street car on a race track? Really?! It was appealing and intimidating at the same time but, with the HPDE novice format, all fear went away and we had so much fun it was hard to articulate.

I am still good friends with a couple of those early Boxster owners that met that first day at Thunderhill.

Slippery Slope

Of course, dear CRN reader, you know the general direction this story is headed. But what I'm told is so unusual (perhaps unique among Spec Boxster race cars) is this original owner car, custom ordered and driven off the lot, that would undergo a multi-year transformation into full-blown race car, while its owner transformed into a race car driver. Not a donor, second hand or salvaged car; an original owner Boxster, transformed.

An ever-increasing number of track days appeared on my calendar. I got better, learned a lot, became somewhat of a web resource for simple 986 DIY maintenance info, bought a spare set of wheels for R-comp tires, a small tire trailer and tow hitch, a roll bar extension, and a hard top. The latter two were requirements for the PCA GGR Time Trial series.

Street/Race Car

A PCA friend suggested that I attend a DE day at Laguna Seca with Checkered Flag Racing, a small club hosting DE / time trial events. It was my first day not at Thunderhill and it was again intimidating at first (lots of concrete walls, many close to the racing surface). I began attending CFRA events regularly and eventually lent a hand running the club and served on the board of directors.

In 2001 I gained my CFRA race license and began modestly racing the car. Still, the car was a daily driver, in great condition, providing reliable transportation.

The only performance updates at this point were competition tires and camber plates. The car saw race tracks all over California and a few occasions in Nevada.

The Conversion

In 2005, the car took its first real turn towards becoming less of a street car: suspension upgrades in the form



of PSS9 shocks and stiffer/adjustable sway bars. Lap times dropped a small but noticeable amount with this change, and the car stayed in this form for several years more. Then, in 2011 I decided that it was time for a new era: a Spec Boxster. The decision emerged from a bunch of rationalization and consequences that somehow all fit together. First, the car was 13 years old so, while it was still my beautiful little corner carver, its market value was no longer a significant consideration. Second, it was a reasonable point in time to get a newer car; one which could be (would need to be) a tow vehicle. Third, the relatively new Spec Box-

ster (SPB) class was now well-defined (and, I later heard, was to some small degree informed by my early efforts and reports in putting the car on track with a few upgrades). Finally, the SPB rules coincided well with my existing suspension upgrades (swapping out camber plates for GT3 control arms), so that part of the DIY conversion cost was pretty much a "freebie" (though more would be needed).

I spent most evenings that summer in the garage, stripping everything down and selling as much as I could. I was pleasantly surprised to rake in several thousand dollars for used parts (things like leather interior

parts, convertible top, interior carpet tub, even the heater core). Not bad for cast-off parts from a car worth perhaps \$10,000. Once the interior was fully gutted, the next task was to take the car to local guru TC Design to have a roll cage fabricated.

Along the way, my original engine expired with over 140,000 miles, at least 25,000 on the track.

Soon the car was fully equipped with the required SPB class upgrades and safety equipment for Spec Boxster racing. Though I say "fully equipped", we all know that there is always more to do. There was no data logging, no radio system, no driver cooling, and far too much wiring and other dead weight still in the car.



Club Racing

The car's debut in SPB form came in March 2012 at Sonoma Raceway, followed by my first PCA Club Race at Thunderhill two weeks later. We had wet, wet/dry weather, and I was very happy to do OK, take practice starts, take P2 in the wet in my first PCA Club Race, and complete an enduro. Not a bad start.

Still, it was clear that despite the significant weight loss to the car, I'd have to learn to gain confidence in driving it faster. I figured that I had so many laps in the car with its previous capabilities that I would need to unlearn driving the old familiar, comfortable limits.

My second Club Racing weekend, in May at Laguna Seca, was a hard lesson. In the first sprint race, in an admittedly small SPB field where the normally fastest guy was new to the track, I was fastest SPB and leading the race easily with two laps to go when my fourteen-year-old transmission let go. My first club race class win would elude me for another full year!

In 2013, the Nor Cal SPB field continued to grow. I did five weekends, including a trip to the inaugural PCA Club Race at COTA. It was a splurge and big undertaking, but wow! Having watched F1 racing there in person, the opportunity to

be one of the first amateur racers to drive there was irresistible. COTA was an extremely fun and challenging track to learn. I'd recommend to any who can manage it to make the trek at least once.

My run group was 70+ cars (20+ SPB). I ran solidly mid-pack which, while humbling, was nonetheless a blast. I'll be back. Later that season, I was able to get my first race win and consistently (other than at COTA!) place on the podium. By the end of the season I had racked up enough good results to finish 6th place nationally in the SPB class.

PCA West Coast Series

In the subsequent years the SPB class has continued to grow. In 2015 I ran all five Club Racing weekends in Nor Cal, part of the West Coast Series started in 2014. The West Coast Series consists of all CR events west of the Rockies, 7 to 10 race weekends, scoring the PCA points for the West Coast Series championship.

By now I was more accustomed to the car, and the car was better equipped and a bit closer to spec weight. At Thunderhill for the first event I did OK, but no podium. At Buttonwillow, the second event, I inexplicably swept all three races! At

Laguna Seca, the third event, I took P2 in both points races, and back at Thunderhill I was able to get on the podium for one race.

Consistent good performance, sufficient attendance, no mistakes or mechanicals, some podiums, and the occasional win set me up for a showdown with my good friend Doug Boccignone for the final weekend at Buttonwillow to go for the series win. I led by a few points going in; if I could stay within one position of Doug in each race I'd come out ahead for the championship. I got the upper hand in qualifying and was just able to stay ahead of him in Sprint Race #1 despite his turning slightly faster laps.

Then the weather hit hard before Sprint Race #2. The race started with a soaking wet track and light but lessening rain, presenting a choice in tire strategies. I opted for rain tires; a couple of guys gambled on dries. In the end, the gamblers lost and I went on to win the final points race of the season and take home the West Coast Series win for 2015.

I don't think it'll happen again! The field continues to grow with faster drivers, which is a great thing.

2016 was a rough year, which included my car getting hit pretty badly in the second practice session by

PUMA AVANTI
FIA APPROVED (8856-2000) | SFI/5 APPROVED

The **Avanti** utilizes revolutionary and proprietary advancements in material, form, function and design synthesizing the ultimate drivers environment for performance and endurance. Lightweight and breathable quilting of a unique 3-layer design consisting of an Aramidic outer layer, a Nomex waffle inner layer, and PUMA's new proprietary 'middle layer' offers an unmatched **33% weight reduction**, an **increase in permeability (breathability) by 55%**, and a **higher thermal protection by 11%** over other manufacturer's 3-layer lightweight designs.

- Anatomically correct pre-shaped body, legs and arms create less bulk in the driving position, increased freedom of movement and agility
- PUMA's proprietary EMS system reduces the weight/bulk in the shoulder area optimizing the acceptance of Hans restraints
- Superior driver comfort is achieved through 'seamless' seaming, along with a large lower lumbar stretch panel to reduce pressure
- Weight comparison: 240 gr/m2 (33% lighter than other light-weight suits). FIA approved (8856-2000) and SFI 3.2A/5 approved

Choose from:
 • Black/white/red
 • Red/black/white
 • Blue/black/white
 • White/black/red
 • Grey/black/white

EVERFIT + PRO
FIA 8856-2000 APPROVED | SFI 3.3/5

PODIO GLOVE
FIA APPROVED (8856-2000)

Authorized Centers		Spring Mountain Motorsports	NV	775-727-6363
Air Power Racing	UT	Track First	OH	234-380-5978
Driver's Edge Autosport	BC	Wine Country Motor Sports	CA	707-935-7223
Framor Safety	MX	Wine Country Motor Sports	CO	303-799-6606
Performance Speed Tech	TX	Wine Country Motor Sports	FL	561-748-5328

To find a dealer near you: **(714) 847-1501**
or find us on the web at: **puma.subesports.com**

Subé Sports is the exclusive distributor of PUMA Motorsports products in the USA.
www.subesports.com



an out-of-control, out-of-class car at Auto Club Speedway. I also began to notice the car reacting horribly to minor surface bumps—a real confidence killer in high speed corners. I came to realize that the shocks, now twelve years old, were overdue for a rebuild. Over the winter I had the shocks rebuilt and started 2017 in shakedown mode to work out the little glitches from reassembly, like ABS sensor failure and another broken suspension component. Once the problems are settled I'll look forward to a more relaxed schedule the rest of the year. In addition to visiting Laguna Seca again, Club Racing is finally coming to Sonoma, the most difficult track around. In the San Francisco Bay Area we're spoiled to have three top notch tracks within a two hour drive, and another fun track four hours away.

I still have more work to do. I've yet to dive into data analysis and improve my driving analytically. I'd like to move the fuses, relays, and immobilizer box. There's a ton of excess wiring under the dash. The inside door pulls aren't great. The rear window was not cut quite right. The radiator fins are looking tired. The transponder gives a weak signal. I recently created a nice gouge in the front bumper with my garage door. It never ends, but transforming the car continues to be as much fun as transforming the driver.

Conclusion

The PCA Spec Boxster ranks have steadily grown since 2008 (yearly national car count according to Rennpoints: 10, 37, 54, 60, 57, 69, 115, 131, 137). In most parts of the country there is a strong level of attendance, and everywhere there are very talented, fast drivers, who know how to get the most out of these great cars. There are tough race battles to be had throughout the field whether you are a hot shoe or not, and the people are terrific. Almost any mechanical problem on race weekend can be solved same day with help from competitors and the



community's supply of tools, spares, and expertise.

What are the weaknesses of the platform? Transmission failures are the most prominent. Fortunately, used transmissions are pretty cheap, and as a group we have enough knowledge to swap in a new one in a couple of hours.

The strengths are clear and well-known. The cars handle great, brake amazingly and, although they are definitely *momentum cars*, they provide enough power and speed to put them on a fine edge in fast corners. How aggressive are you willing to be as you transition left-brake-right in Turn 10 at Sonoma, approached at

105+ MPH, with that big wall looming in front of you across a negligible patch of grass run-off, and a concrete barrier lining the opposite edge of the track? The fastest drivers have the skilled confidence to brake less and get on the gas earlier, while the rest of us leave a few miles per hour on the table there.

For me, corners like that are intense, but though my competitor may gain on me, I'm satisfied that the super cool car I custom ordered in 1997 is back in my garage at the end of the weekend, still lookin' good, adorned with a few decals and scars it has earned doing what I think it was truly built to do. 🏁

Porsche® Cup Car related products and services



New Cayman Air Jack Retro-fit Kits Available Now
Complete with hose, fittings, air jacks and air lance

Mounting tubes/gusset plates also available









4421 Wild Turkey Way | Gainesville, GA 30506 | 404-992-0809 | jackgilsdorf@mac.com | www.cupcarsolutions.com



Bosch Motorsport MS3 Sport ECU
Programmable Engine Management for GT3 Cup



Bosch Motorsport M4 Clubsport ABS
Affordable Motorsport ABS System using the same M4 Control Unit with universal wiring loom



Bosch Motorsport
Authorized Dealer



108 Podiums
45 Wins
10 Track Records
2 National Championships
2016 PCA Club Racing

Now a Bosch Motorsport Authorized Dealer

843.763.7356

autometricsmotorsports.com



MCS Authorized Dealer



2017 PCA CLUB RACING NATIONAL SPONSORS

Club Racing Sponsorship Information: 410.381.0924 executivedirector@pca.org
Club Racing Forms / Schedule: <https://www.pca.org/club-racing>
Club Racing News: <https://www.pca.org/club-racing-news>

Club Racing Office
847.272.7764
pcaclubrace@aol.com



www.us.pirelli.com



Porsche Cars North America
www.porsche.com



866.325.5426
www.jx2pg.com



RACE FUELS
800.722.3427
www.racegas.com



866.582.4957
locktonmotorsports.com



704.799.3800
<http://www.motec.com>



973.773.3177
www.stableenergies.com



877.TRAILEX
www.trailex.com



800.934.9122
www.ogracing.com

PORSCHE DESIGN
TIMEPIECES
www.porsche-design.us



800.797.2911
www.gt-racing.com



865.200.4264
www.performanceracingoils.com



866.505.2739
www.apexperformance.net



driven to perform®
<http://toyotires.com>



866.201.1977
www.motioncontrolsuspension.com



704.450.4507
www.racetech-usa.com



773.286.5881
www.inglot.net



843.524.8473
www.bobwoodmantires.com



800.542.0972
www.hawkperformance.com



800.722.3234
www.michelinman.com



info@softronicsoftware.com
www.softronicsoftware.com



512.273.5016
<http://register.pca.org>



Be Smart, Not Sorry

Winners Do The Research



FORGELINE

CUSTOM BUILT • LIGHTWEIGHT • FORGED ALLOY WHEELS

800-886-0093 WWW.FORGELINE.COM

AMERICAN DESIGNED AMERICAN MADE



ROAD (RACING) TRIP

ROAD ATLANTA, LAGUNA SECA, DAYTONA, WATKINS GLEN, CIRCUIT OF THE AMERICAS...

STORY & PHOTOS BY PAUL D. YOUNG

Road Atlanta, Laguna Seca, Daytona, Watkins Glen, Circuit of the Americas... All revered and famous tracks. And we in PCA are so fortunate to have races at these wonderful venues. My favorite (so far...) is Laguna Seca. I like to say "Laguna Seca, not a great race track because it's famous; it's a famous race track because it's great!" But there are many more gems of asphalt around the continent that are very worthy of spending the time and effort to visit (High Plains, Roebing Road, Mid-Ohio, Barber, Mosport, Thunderhill, Hallett – I could go on and on).

While Laguna Seca is only a day's drive from my home, I have truly enjoyed many terrific tracks much far-

ther away. And, there are still more that I simply need to get to drive before too long!

One really great benefit of PCA Club Racing is the consistency of many of the logistics involved. First, the registration process is all done through the same on-line site, no matter when or where the race is located (ClubRegistrtration.net). This site lets you search for club racing events coming up soon (but you also can check the PCA Club Racing schedule on the main PCA website). With your car(s) and class(es) already in the system, it's a simple matter to select your car when registering. The registration site has a lot of useful information to plan your stay (hotels,

maps, local contacts, etc.). The local contacts I have found to be especially helpful in particular - hospitable, and welcoming.

This consistency extends to the running of the event itself. There is a well-qualified pool of PCA National Club Race Stewards, Scrutineers, and Timing staff, and every PCA race uses these folks exclusively to run the event. Sure, it also takes a team of local volunteers helping out, but the racing itself is always run by National staff. This provides a comfortable, familiar, and consistent format, rules, and operation for all participants.

You can go to a race anywhere, and know exactly what to expect. This

ACCESSPORT TUNED

World Fastest Turbo S
EkanooRacing

1/4 Mile Record 9.397 @ 146MPH

1st Place - Time Attack 2
Porsche of Colorado Springs

2015 Pikes Peak International Hill Climb

Predator Performance

World Fastest 991
TURBO

1/2 Mile Record @ 177MPH

World Fastest Turbo S (Stock Turbo)
Vengeance Racing

1/4 Mile Record 9.717 @ 143MPH

ACCESSPORT
THE COBB ACCESSPORT V3 FOR PORSCHE
981 | 987.2 | 991 | 997.2 | 997.1 | 996

Easy handheld DME/ECU flashing anywhere, anytime. Live engine parameter feedback and datalogging. Free, pre-programmed maps for common modifications. Fully featured custom tuning software for any modification level. The only engine management system you will ever need.



COBB
PLANO

COBB
SURGELINE

COBB
SOCAL

www.cobbtuning.com/porsche

COBB

consistency extends to the racing itself. All cars are classified using the same rules, so others in your class (or similarly performing classes) should be benchmarks on the track for you. All your personal safety gear and safety items added to your Porsche will be valid at any venue. And, all drivers' behavior regarding safety, passing, and sportsmanship is expected to be to the same high standard regardless of where the race is being held.

Besides visiting awesome new tracks, there are other advantages of travelling to a distant PCA Club Race. First, you'll meet some great folks – "It's not just the cars, it's the people". As I mentioned, the local PCA members have always been very friendly, hospitable and helpful. Whether it's favorite local restaurants or a good place to get car parts and supplies, they seem to go out of their way to make the long-distance travelers feel welcomed.

I've made some new friends going to tracks that were more than a day away. Plus, when I return to these tracks, I have more to look forward to than just racing – I have friends to visit! Some of the new friends have decided to make the trip to my "local" tracks. And, you never know who you'll run into. While at a PCA Club Race at Mosport (an extremely fun track, by the way), I ran into a friend from California I used to race with regularly. I hadn't seen him for a few years - Seems his work transferred him to Pennsylvania, and he was exploring the many wonderful tracks near his new home. We had a great time racing together, and catching up on old times.

One interesting benefit I have noticed is that the more different tracks I drive, the quicker I seem to learn a new track. Mind you, it isn't that I master it right away, but I have been aware that I seem to pick up the line on a new track quicker than I used to. Other drivers have noticed the same thing for themselves, and I have to attribute this to the wider variety of courses I try to experience.



Alright, how does one go about visiting a PCA Club Race at a track that isn't quite in the neighborhood?

Over the years our family has faithfully attended Porsche Parades. These huge, week-long events with over a thousand enthusiasts, and hundreds of Porsches of all types have tours, social events, banquets, technical presentations, lots of kid activities and competitive events. We see friends from all over the North America (and further abroad), many we only get to see at Parade.

Since the Parade is held in a different part of the country every year, we consider this an excuse to visit

places we haven't explored. We almost always drive to Parade, and visit friends and parts of the USA along the way. On occasion we'll pack up the race car and trailer and plan our route to attend a PCA Club Race or two (or more!) on the way to or from the Parade.

Although it can be difficult to arrange, occasionally a Club Race (or DE) will be scheduled near the Parade location and on a weekend adjacent to Parade. This is intentionally done to encourage attendance at both events, and I certainly suggest you take advantage if the opportunity arises. Doing this, we have been able to drive a number of wonderful

EBS Racing is your MAHLE motorsport Preferred Dealer!

MAHLE
motorsport
Master Distributor

A shipment of **Porsche Mahle Motorsport Pistons** has just arrived.
Call or email for current price and availability!

Set Number	Description
PS80-001	PORSCHE 911S 2.0L 9.5:1
PS84-001	PORSCHE 911S 2.2/2.4L (2.2 9.3:1CR 2.4 9.5:1CR)
PS86-002	PORSCHE 911S 2.5L 10.3:1
PS98-005	PORSCHE 911 3.0-3.2 CIS 9.8:1 (Wedge Dome Max Moritz Style)
PS98-009	PORSCHE 930 TURBO 3.4L 7.5:1 (3.3-3.4)
PS98-010	PORSCHE CARRERA 3.2-3.4L 9.8:1 (3.2- 3.4 Motronic inj.)
PS102-017	PORSCHE 964 NA 3.8L 12.3:1 (107mm slip-in cyl 3.6-3.8)
PS102-018	PORSCHE 964 NA 3.8L 12.3:1 (bore in 109mm cyl 3.6-3.8)
PS102-019	PORSCHE 993 TWINTURBO 3.8L 8:1 (109mm bore in cyl 3.6 TO 3.8)
PS102-020	PORSCHE 993T 3.8L 8.5:1 PP102- 013 (107mm slip-in cyl 3.6-3.8 NA to Turbo conversion)
PS102-021	PORSCHE 993T 3.8L 8.5:1 PP102-01 (109mm cyl bore in 3.6 TO 3.8)
PS102-02	MMS 993 RSR 3.6L 11.4:1 (107mm slip in cyl 3.6 TO 3.8)
PS102-023	MMS 993 RSR 3.6L 11.4:1 (109mm bore in cyl 3.6 TO 3.8)
996 103 915 3.8 MA	PORSCHE 996TT 3.8 liter (102mm 23mm pin 9.4:1CR 3.6-3.8)
996 103 942 3.8 MA	PORSCHE 996 GT3 3.8 late (102mm 21mm pin 12:1CR 3.6-3.8)
996 103 942 4.0 MA	PORSCHE 996 GT3 4.0 late (105.4mm 21mm pin 12:1CR 3.6-4.0)
997 103 915 3.8 MA	PORSCHE 997TT 3.8 liter (102mm 23mm pin 9.4:1CR 3.6-3.8)
997 103 938 91 MAH	PORSCHE 997 GT3 (102.7mm 21mm pin 12:1CR 3.6-3.8)

Need piston rings?

Call or email with application, thickness, and ring diameter for a price quote.

Have a custom application or need a piston set not listed?

Call or email with details. We can have your custom piston made to your specs by Mahle Motorsport, Je Pistons or CP Pistons.

Need a single piston or cylinder?

Call or email for price and availability.

Join Team EBS Racing

Dealers and customers: join Team EBS Racing to receive our newsletter filled with new product releases, tech info, photos, videos and more. Sign up this month and receive a free pdf copy of the 2016 Porsche Cayman GT4 Technik Introduction. **Sign up at www.ebsracing.com.**



EBSracing.com

email ebsracing@aol.com

toll-free **800-462-3774**

international **775-673-1300**

international fax **775-673-2088**

4068 S. McCarran Blvd. | Unit B | Reno, Nevada 89502

tracks outside of Southern California, including High Plains Raceway, Mid-Ohio, Miller/Utah Motorsports Park, Mosport, Portland International Raceway, Road Atlanta, Roebing Road and Watkins Glen. In 2013, Paul Jr. took top overall Parade autocross time with our 911SC (only 191HP, but light and nimble)!

Most club races have tire vendors on-site, so you can work with them in advance to ensure that they have tires for you. So, if you are not a Parade attendee, check it out and sign up! Then, when you are a Parade attendee, look for PCA Club Races (or DE events), nearby or along the route to and from the Parade.

A fun planning activity would be to get out a map and a club racing schedule and plot out a route that would take you to various scheduled events. You could visit relatives, friends, national parks, other PCA regions, and a bunch of interesting places in between races. Depending on your available time and financial resources, you can also consider having your race car shipped to the destination events, and flying to a nearby airport. If a group of you from your local region get together, you can fill up a transport with your race cars and drive separately or fly to the destination tracks.

Who says you need to stay away from home all that time?

I've also hear of people driving to a long distance venue, enjoying the race weekend, arrange to leave their rig with a friendly PCA'er, fly home (one way to use those miles), then fly back at some later point (based on the schedule you've come up with), drive to that next venue, enjoy the weekend, then repeat the routine until you've had enough. Can you imagine how much fun you'd have, the places you'd see, the people you'd meet? Good thing I'm retired!

I knew a PCA couple in the late 1980s who retired, and then immediately spent the better part of a year travelling the USA. They took their modest motorhome and trailered



their 914-6 all over. The club racing program was not around yet, but they looked for DE events in various PCA regions across the land. Seems to me they did over forty events in their year on the road. They met many wonderful PCA folks, drove all sorts of tracks, saw some incredible sights along the way, and generally had the time of their lives. What few automotive problems they encountered were met with support from the many helpful PCA friends they made along the way. While not all of us could take a year for this, you have to admit it has tremendous appeal.

So take a look at the PCA Club Racing calendar, check out the Porsche Parade, and work the two to-

gether – you'll have more than double the fun! Or simply start out by planning a longer trip to a PCA Club race a bit farther away than usual.

In 2017 the Parade is in Spokane, WA in early July, but by the time you read this, it will be a bit late to sign up. For 2018 the Parade will be located at a nice resort in the middle of Missouri (Lake of the Ozarks). We are already thinking about the 2018 Parade, and when the PCA Club Racing schedule comes out (near the end of 2017), we'll be busy planning our excellent adventure of a PCA Road (Racing) Trip!

So, have fun, and we hope to see you on the track soon – maybe one far from our homes! 🍀



CARQUIP

Porsche Parts & Transmission Specialists

Contact us at: email@carquip.com

Transmission Sales & Build-to-Order
741, 901, 911/914, 915, 930, G50, G64

- Full Service Factory Spec Rebuilds
- Full Service Race Charts & Builds
- Custom V-8 Conversion Specialists "Tips"
- Custom Off-Road, AutoX, Hillclimb, Rally, & Road Race
- Largest Inventory of NOS, New, Used Transmission Parts in the Country
- We also buy good used and core transmissions

356, 911, 914, 944, 930 Engine Components

- Cases, Manifolds, Carburetors, Cams, Heads
- Cranks, Piston & Cylinders, and just about anything you might need for your project...

356, 911, 914, 944, 928, 930 Body Parts

More than 800 Porsche's dismantled!!

- Fenders, Doors, Hoods, Glass, Trim, Wheels, Interiors, and much, much more...

CUSTOM MANUFACTURING OF THE FOLLOWING:

- Twin Plug Distributors (2.0L - 3.6L)
- ZF Type LSD's and Torque Bias Diff
- Aircraft Quality Gears (741 - G50)
- 911 Billet Aluminum Intermediate Plates
- Special Ratio R & P's (741, 911, 915, 930, G50)
- 904 Mainshafts & 904 Special Ratio Gears
- 915 Stainless Bearing Retaining Plates
- 915 Mainshafts w/ Active 1st Gear

WE ALSO BUY & SELL PORSCHE'S !!



www.carquip.com

7191 Arapahoe Ave - Boulder, CO. 80303

303.443.1343



Driver Coaching and Development

"The biggest improvement to our program was Mike Zimicki!" Race winning IndyCar engineer

Michael Zimicki

Building racers since 1981

Coaching first time drivers to IndyCar winners
 Individual and team coaching available
 Let's work together to find the speed within you!

Some successful clients:

Ryan Huner-Reay, Graham Rahal, Danica Patrick, Jon Fogarty, John Edwards and others

614.270.3141

mfzcoach@yahoo.com

www.SlideRuleMotorSports.com

58

CLUB RACING NEWS

JULY - SEPTEMBER 2017

59



Coaching Perspective

DAVID MURRY • CLUB RACING DRIVING COACH

PASSING ON SORT OF STRAIGHTS — RESPONSIBILITY?

We all think about passing in the brake zone or corners, but we don't think as much about passing on straights. We take passing on straights for granted. We get a run on someone or get a nice draft and sling-shot by. In reality, we should think about passes on straights as much as the other, not only complete a pass but also to avoid contact.

While the primary responsibility lies with the passing car (car 2), the car being passed (car 1) shares responsibility for a safe pass as well.

The scenario that comes to mind is passing on a straight where the exit of the corner leading onto the straight (turn 1) is the opposite side of the track from the turn-in point of the corner at the end of the straight (turn 2). As car 1 crosses over to the right side of the straight setting up for turn 2, there is risk of car 2 coming into contact with car 1. Car 2 should be aware of the normal line that car

1 plans to drive, crossing over from one side of the track to the other. If car 2 gets a run on car 1 and makes a pass later on that straight, he will most likely pass car 1 on the inside of turn 2 after car 1 moves over setting up for that corner. That would be the safest pass. However, if car 2 gets a run or has a lot more power than car 1, he may initiate his pass right after turn 1 exit onto the straight. This has more risk because car 1 plans to move in that direction, setting up for turn 2.

Car 2 has the responsibility to make a safe pass, but as car 1 crosses from one side of the track to the other, he has a responsibility to not squeeze car 2 off the track or have contact with him.

This is a common challenge for what should be a safe easy pass. Car 1 may be driving a fast corner and not expect car 2 to get a run so early, but car 1 must simply look for cars be-

fore crossing the track. Car 2 should also think before making the pass on that side of the track before car 1 moves over. Car 2 needs to think about whether he can get by before car 1 could move over (in case car 1 doesn't see him). If car 2 can wait, he knows car 1 will see him on the inside of turn 2 and avoid the possibility of contact. Simply put, both cars share responsibility.

If a faster car catches a slower car, they should not expect the slower car to just allow them to pass. Car 2 needs to be aware that how car 1 is going to make it difficult to be passed. This now becomes more intentional by car 1 to drive a *wide* car. Car 1 also needs to be aware that car 2 wants to get by and may be faster. Now it's not a matter of whether car 1 sees car 2. Both are now playing the chess game of positioning their car to take the next corner.

Both drivers need to know when they have been checkmated and give the corner up. We all want to prevail, we all want that corner, but only one can (and it is NOT always you!).

Think about the big picture and evaluate the risk/reward of a pass before you attempt it, and be aware of cars around you and the situation.

Don't force something just because you want it; evaluate the situation objectively and make the correct decision. Those trips up to the tower to visit the steward are not fun. 🏁

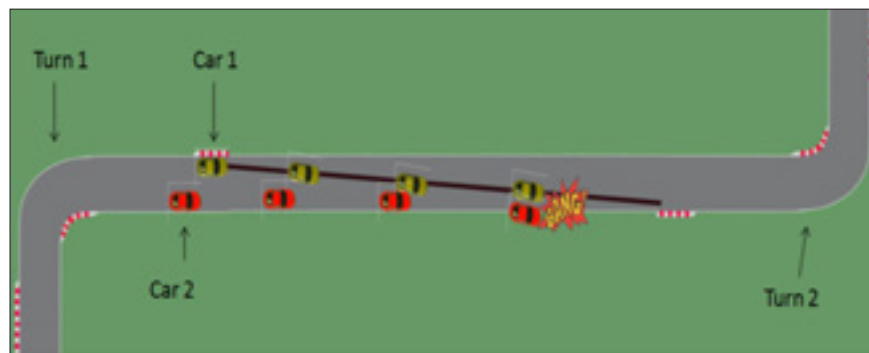

PCA CLUB RACING CONTINGENCY PROGRAMS

BY STEVE RASHBAUM

Below is an outline of the various contingencies available to racers. An overview of the award guidelines and forms can be found at: www.pca.org/rules-licensing-forms



Bob Woodman Tires:

- All classes running on Hoosier, Toyo or Yokohama tires.
- Guidelines/forms at: www.BobWoodmanTires.com/PCAcontingency



Pirelli/JX2:

- All classes running on Pirelli tires.
- Guidelines and forms can be found at: <https://jx2pg.com/contingency/jx2-contingency-form/>



Toyo Tires:

- SPB and SPC classes
- Guidelines and forms can be found at: www.toyoracerrebates.com



Hawk Brakes:

- SP1-3
- One set of brake pads to class winners of championship points races having more than 5 starters.
- Certificates will be sent to winners.



Pirelli/JX2:

- GTC3-6
- Tires awarded to class winners of championship points races having more than two starters.
- Certificates will be sent to winners.



Pirelli/JX2:

- GTB1 "Triple Trofeo Championship".
- Guidelines can be found at: www.pca.org/rules-licensing-forms

We would like to thank our sponsors for their generous support of PCA Club Racing



MONEY, BEAUTY AND HP

THE THREE THINGS YOU CAN NEVER HAVE ENOUGH OF

STORY BY PEDRO P. BONILLA (GCRPCA)

Regarding the first two, it's best if you're born with them. Luckily, the last one, horsepower, is much easier to get, and I'll tell you how.

One of the most-asked questions in Porschedom is: "How can I get more HP out of my car?" In many instances people spend a ton of money purchasing expensive and exotic intake or exhaust systems and other aftermarket add-ons, only to find out that they've lost, not made, horsepower.

Why does this happen, you may ask? Because of a little box called the DME. I'm sure you've heard of it, but maybe you don't know exactly what it is and what it does. Let me try to explain.

DME stands for Digital Motronic Electronics, or actually, Digitale Motronic Elektronik (in German). It was originally designed by, and is still manufactured by Porsche's electronic supplier: Bosch GmbH, although the newer Porsches are now using the Siemens DME, but the principle is the same. It is also known as the ECU which stands for Engine Control Unit or Electronic Control Unit (see photo above).

Simply put, the DME (or ECU) is the engine's management computer, which is programmed at the factory to provide the best combination of power and fuel economy for a myriad of driving conditions. This engine management system will actually

work against any changes you make to the engine's systems and will try to bring the parameters back to standard. That's why you may lose power with some aftermarket products, but there's a way around that... later.

How and why was the DME developed?

The first Porsches of the very late 40s through the early 70s used carburetors and distributors for engine management. It worked well until we needed better emission controls, which forced manufacturers, including Porsche, to develop fuel injection. The new management system now needed an analog computer to control the amount of fuel the en-

gine would receive by varying the time the injectors were open. The first Porsche engine management computers were the Bosch D-Jetronic and they were controlled by the engine's vacuum. It was first introduced on the 1972, 2.4 liter 911T and came on subsequent Porsche models. Using the vacuum was not very efficient, so Bosch eventually advanced to the Digital Motronic Electronics (DME), still in use today, although immensely more refined than the first versions.

These systems were much more precise. Gas mileage and performance were dramatically increased while emissions dramatically decreased.

Today, our DME does much more than just control the fuel injection. It controls everything related to the engine, from measuring the incoming air temperature and ambient air pressure, to the amount of fuel injected, to the throttle position, to the amount of air flowing into the engine, and many other parameters. Then, based on its memory's maps, it makes a decision as to what's the best combination of air, gas and spark timing for that particular situation, and maintains it for maximum performance and fuel savings.

Using the information about how much air is flowing through the engine (sensed by the Mass Airflow Sensor - MAF) and how fast the engine is turning (RPMs), the DME uses a fuel map to determine how long each injector should stay open during each cycle to inject the correct amount of fuel.

During partial-throttle operation, the injector pulse-width is also modified by the readings from the oxygen sensors, devices that sit in the exhaust collectors and determine how much oxygen is left over in the exhaust. Each cylinder is constantly adjusted to obtain maximum operating efficiency under virtually all conditions.

In the event of an electrical or electronic fault, the DME can even reconfigure itself to bypass the problem and it can self-diagnose for quick and efficient troubleshooting.

That's why, even with a failed MAF, for instance, the DME goes into a "safe mode" and keeps the engine running safely and efficiently. If this happens, it will also alert the driver via the check engine light (CEL) so that it can be corrected by a service provider.

At the core of a DME there are multiple microprocessors, and in a modern Porsche they execute nearly twenty million instructions per second (20 MIPS). Microprocessors also have a reputation for being extremely reliable. They are designed for a lifespan of at least 150,000 active hours. A car, by comparison, is expected to survive around 4,000 hours of use (a race car much less!).

The Porsche ECU is typically located under one of the front seats (911) or in the rear trunk (Boxster).

The Porsche DME is a very reliable and rugged piece of engineering. It is quite durable and trouble-free. Nevertheless, having said that, the number one cause of a Porsche's DME unit failing can be caused by jump-starting the car using cheap jumper cables, which may cause the electrical system to surge after the vehicle is started. Another common failure can occur when an enthusiast (or a shop) uses an electric welder and fails to first disconnect the ground cable on the battery, causing a high voltage surge through the ECU.



ECUs are very complex computing systems and can be very expensive, costing as much as \$5,000 or more to replace. Luckily, many failed ECUs can be repaired quickly and affordably by a few highly-specialized repair facilities around the country.

How to make more horsepower

Let's get back to how to make more horsepower on your Porsche. When Porsche manufactures a vehicle they don't generally know where the car will end up and under which conditions it will be driven, so they *de-tune* the engine through the ECU maps to allow for a multitude of adverse driving conditions, such as using low octane fuel, driving at high-altitudes, under very hot ambient temperatures, etc.

But you can narrow the parameters dramatically by having your ECU reprogrammed to the conditions you will drive under, such as: Street, Spirited Driving, AX, Track, full-blown Racing, etc. For instance, if you only use 93 octane gasoline, the ECU can be reprogrammed for that.

If you've installed aftermarket intake and or exhaust systems, the ECU can be reprogrammed for that.

If you've increased the throttle body's size, the ECU can be reprogrammed for that.

If you'd like to raise the rev-limiter, the ECU can be reprogrammed for that. If you've ... you get the idea.

All of this collected information is optimized, converted into data and maps and can be reprogrammed into the ECU's memory during the Chip tuning or Flashing process. Once the ECU is *Flashed* with its new maps, the engine's data is now processed with the new parameters and significant gains in torque and hp can be achieved. Horsepower and torque increases of 20-30% are possible for turbo-boosted engines, while 8-12% gains are the norm on normally aspirated engines.

The recommendation is to make all the changes to the hardware (engine intake through exhaust) first, and as a final step flash (reprogram)

the ECU so that it knows which changes to consider and incorporate. If you don't follow this plan you'll have to flash every time you modify any physical engine component in order to obtain significant gains from that particular mod.

You may also hear the process of flashing a DME referred to as *chip* or *chipping*, and that's because the first generations of DME used ROM (Read Only Memory) chips that could not be re-programmed. Many *tuners* today still have to crack open the DMEs case and remove, re-flash, and re-solder the physical chip in Porsche models up to 1998.

Today, some very exclusive *tuners* with state-of-the-art computing hardware and software can read and

reprogram your car's ECU without opening its case. It's all done through the DMEs existing 88-pin connector, even on the first generation 986 (Boxster) and 996 (Carrera).

Other software upgrades and re-maps on model year 2000 and newer can be done directly through the OBD-II port on your car.

(see figures connector1, connector2, connector3 and flashing.

There have been great advances in ECU reprogramming in the last few years. Some services which were considered impossible on a Porsche's DME, are now available to the general public.

I'm very aware that this article is being published in PCA Club Racing News and it is in no way to be



connector 1



connector 2

DEMON SPEED MOTORSPORTS

HIGHLY ENGINEERED SOLUTIONS FOR YOUR PORSCHE MOTORSPORT NEEDS.

Competition Suspension Components

AHEAD IN NECK PROTECTION

Wing uprights 4" to roof height featuring custom colors and designs.
 Boxster/Cayman Splitters, Ducktails, Diffusers
 996 and 997 Double Height Jack Stands.
 Brake Pads and Rotors.
 CSF radiators.
 Helmets, belts, neck harness for all the personnel protection requirements.
 All Maintenance and Spare Parts in One Easy Stop.
 New and Used parts available.
 Custom Design and Build Solution

Don't Just Get FAST.... Get Demon SPEED
 (216) 333-1200 demonspeedmotorsports.com sales@demonspedmotorsports.com

DECADES LATER, STILL THE BEST.

- ESTER BASED: BETTER FILM STRENGTH THAN BRAD PENN AND DRIVEN!
- MORE THAN 2200PPM OF ZINC
- LONGER DRAIN INTERVALS
- REDUCED FRICTION FOR LESS WEAR AND INCREASED POWER
- A 15W40 FOR AIR-COOLED AND WATER-COOLED PORSCHEs

To find your local dealers or distributors: 800.624.7958 | REDLINEOIL.COM



considered as a recommendation to blindly remap your ECU. Please check your particular Class Rules in order to determine if it is allowed (as in the Prepared and Modified Classes). Many PCA Club Racing classes do not allow any changes to the software, such as most Stock and Spec Classes (this includes Boxster Spec, Cayman Spec and 996 Spec Classes).

Modifying the ECU maps where prohibited is a violation of PCA's Club Racing Rules and will have consequences. Scrutineers now routinely check for illegal ECU maps and chips by downloading a racecar's map and comparing it to the OEM map for that car. To obtain additional information about *chipping* or *tuning* your

Porsche and more, please visit my website at: www.PedrosGarage.com.

Happy Porsche-ing,
Pedro

Ed: Pedro Bonilla is also one of our PCA Club Racing Scrutineers in addition to owning his own shop in Southern Florida. ♠



TRAQGEAR

Absolutely the best because we listen to our customers. Get safety and performance with TraqGear!



PODIUM LCG
SFI Certified Fire Retardant



RACE PRO
Lightest Most Comfortable
SFI Certified on the Planet

Being cooler means being more alert! Get the TraqGear difference!

www.TraqGear.com



EUROFIT
Semi-Compression Safe and SUPER comfortable



PODIUM HPDE
Comfort Style Protection



PCA Chicago Region's



The Road America Challenge 2017

DE and Club Race

September 1* - 4, 2017
Road America, Elkhart Lake, WI

* Friday: DE and Optional Club Racing Test & Tune (under PCA DE Rules)
Saturday - Monday: DE and Sprint and Enduro Races

944 Cup Midwest Points Races / Triple Trofeo Championship Races for GTB1

Registration opens Monday, July 17th, 9:00 pm CDT

<http://register.pca.org>

Race Chair: Keith Clark kc_design@sbcglobal.net 630.514.5937

CSF COOLS PORSCHE

THE BEST PORSCHE TUNERS USE CSF



Find more at CSFrace.com: News • Blogs • Features
European & International distributors/dealers wanted! Inquire: info@csfpace.com

CSF
Ultimate Performance Cooling

		996/996 CSF	996/996 CSF	996/996 CSF
996 Carrera	Left	CSF	CSF	CSF
	Right	CSF	CSF	CSF
	Center	CSF	CSF	CSF
996 Turbo	Left	CSF	CSF	CSF
	Right	CSF	CSF	CSF
	Center	CSF	CSF	CSF
996 GT2	Left	CSF	CSF	CSF
	Right	CSF	CSF	CSF
	Center	CSF	CSF	CSF
996 GT2 / RS	Left	CSF	CSF	CSF
	Right	CSF	CSF	CSF
	Center	CSF	CSF	CSF
Boxster	Left	CSF	CSF	CSF
	Right	CSF	CSF	CSF
	Center	CSF	CSF	CSF
Cayman	Left	CSF	CSF	CSF
	Right	CSF	CSF	CSF
	Center	CSF	CSF	CSF
C74	Left	CSF	CSF	CSF
	Right	CSF	CSF	CSF
	Center	CSF	CSF	CSF

#COOLisTheNewHOT

Proudly distributed by





International Distributors





Exclusive Dealers









Ferdinand Porsche with his son Ferdinand Anton Ernst "Ferry" Porsche - 1937

HISTORICIZING PORSCHE: THE RUSSIAN CONNECTION

THE RUSSIAN CONNECTION AND WHAT COULD HAVE BEEN

STORY BY ASH SEIDL-STALEY (REPRINTED FROM SLIPSTREAM); PHOTO COURTESY OF STUTCARS.COM

One can hardly turn on the news, regardless of the partisan outlet, without seeing Russia boldly displayed in the headline or, at the very least, shimmying across the banner at the bottom of the television screen. Lt. General Michael Flynn's resignation as President Trump's National Security Advisor and subsequent plea for immunity, as well as updates on the mountain of evidence stacking against Russian President Vladimir Putin, take center stage of this coverage.

It's crazy to think about, but this pattern of attention, conflict, and speculation is cyclical. It has been occurring for decades. I'm not sure how many

people actually remember, but the Cold War, the political witch hunts/trials based on radical McCarthyism, and Reagan's surprising admiration for Gorbachev steered us through much of the twentieth century.

In the 1990s, headlines switched gears when they started describing a broke and socially conflicted Russia. Having just risen out of the ashes of the Soviet Union, Russia was forced to lean on the U.S. and the International Monetary Fund (IMF) for economic, social, and even political support. But this never garnered mutually beneficial relationships. Russia always distrusted the West, and the

West always doubted Russian sincerity. No matter which side of the political spectrum you find yourself on, you can at least agree that Russia is important, that Russia is here to stay, and that both the U.S. and Russia will continue to meddle in each other's affairs for decades to come.

Russia's international meddling stretches far back into history, but for our intents and purposes we should really just start in the 1930s. In his autobiography entitled *We at Porsche: The Autobiography of Dr. Ing. h.c. Ferry Porsche*, Ferry Porsche, the son of Ferdinand Porsche, describes when Joseph Sta-

lin came knocking on his father's office door in Stuttgart.

In 1932, Stalin sent a delegation with hopes of wooing Porsche into adding his expertise to the goals and aspirations of the Soviet Union. "At first we thought the invitation was so improbable we had trouble taking it seriously," noted Ferry. After breaking the ice with an impromptu visit, Stalin then offered Ferdinand Porsche an invitation to go on a tour of the Soviet Union. Porsche accepted the offer and was subsequently conducted around Russia, stopping mostly to admire and view Soviet aircraft and automobile factories.

Once Porsche had a general idea about how Stalin's automobile and military vehicle industry operated, Stalin offered Porsche a prestigious position as his Chief Construction Director, a station that would basically make Porsche the director of the research and development arm of the Soviet auto industry. The job included a hefty sum of money, a villa in the mountains, and even the ability to transfer all of his Stuttgart staff to a new Soviet located workshop.

Ultimately, Ferdinand decided to distance himself from Stalin. Many historians and Porsche fanatics believe that Ferdinand declined because the European Grand Prix did not race in the Soviet Union. He loved to race his cars, especially against rival European manufacturers, so moving to a place where that was not possible was simply just not an option.

Ferdinand's son Ferry describes his father's choice, likewise, in simplistic terms. "After much consideration," Ferdinand turned down the Soviet courtship. He felt that learning the Russian language would have been too difficult. Running a nation's automobile industry was a hard enough task; Porsche could not imagine running the foreign industry when he could not even communicate with his subordinates and supervisors.

Ferdinand's decision to snub the Soviets demarcates one heck of a "what if" scenario in the historical time line of the Porsche, Volkswagen, and Audi automobile brands. Had Porsche said yes to Stalin, would a derivative of the iconic Volkswagen have been produced in Russia? Would

a Russian made car have launched Ferdinand and his successors to the top of the global market for exotic race cars? Or, would the Russian collaboration have been a flop, and the Porsche name forgotten by the year 1960? That's the fun of causal what ifs: we just don't know.

What we do know, thankfully, is that two years after the Soviet invitation, Porsche opened a contract with Reichsverband der Automobilindustrie, initiating the production of what has come to be known as Hitler's "people's car."

But that, my good Porschephiles, is a topic best saved for later.

Further Reading / Resources

Michael Mandelbaum, Mission Failure: America and the World in the Post-Cold War Era (New York: Oxford University Press, 2016)

Ferry Porsche, We at Porsche: The Autobiography of Dr. Ing. h.c. Ferry Porsche (New York: Doubleday, 1976).

<https://www.stuttcars.com/about-porschelferdinand-porsche/> 🇩🇪

AIM Data and Video Products



MXL 2



MXG



SC HD Gen 2



SOLO DL



SC HD GP



EVO 4 w/ G-Dash

Authorized Dealer Since 2008
PCA Member since 1993

Austin Motorsports LLC
www.austinmotorsportsllc.com

Ask for PCA Discount
941 228 8964

EVENT ADS

PAGE	EVENT	DATE
21	2017 West Coast Series — 10 Races	see schedule
66	The Road America Challenge	Sep 1-4
44	Mardi Gras Cup 2017, NOLA	Sep 15-17
17	Rock the Summit Club Race	Sep 22-24
36	Willow Springs Club Race & Time Trial	Sep 30-Oct 1
44	Oktoberfest 2017, Hallett	Oct 7-8
17	Pittsburgh International Race Complex	Oct 13-15

Quick Release Steering Wheel Hub

TC Racing

Order online at
www.tcracing.org
 Tel: 901-767-1111
 Email: tcracingporsches@aol.com

TC Racing's quick release mechanism makes it easy to insert and remove the steering wheel from the hub. Simply pull the twin pins. Direct bolt-on installation to Momo, Sparco and other steering wheels.

- Hub: \$76
- Quick Release and Hub: \$275
- **NEW:** Quick Release for MOMO



(973) 773-3177 175 Passaic St Garfield, NJ 07026 StableEnergies.com

STABLE ENERGIES

MOTORSPORTS

The Largest Distributor of Motorsport Performance & Safety Equipment in the Northeast!



EXCLUSIVE CLUB RACING INSURANCE



On-Track Physical Damage Coverage
 Unlimited Use Annual Certificate Coverage
 Includes Club Racing Test & Tune
 HPDE/DE and Open Track Days

815.725.6527

We Specialize in Motorsports and Racing Insurance

Coverages We Provide:

- Storage
- Transportation and Paddocks (STP)
- Commercial Auto Coverage for Power Units and Trailers
- Race Prep Shop Coverage
- Collector Car Insurance
- See other coverages also available at: www.ChizmarkLarson.com/motorsports.5.html





TWILIGHT CYCLING LAGUNA SECA

2017 MAZDA RACEWAY TWILIGHT CYCLING SCHEDULE OPENED JANUARY 18

HOSTED BY SCRAMP, BAY BIKES AND LIGHT & MOTION, PHOTOS BY DMT IMAGING

Mazda Raceway Laguna Seca \$10 per ride -- helmets required. Parking in the main paddock Bay Bikes will be on site to rent bikes and helmets and provide maintenance. Light & Motion will provide loaner lights.

Riders of all ages and skill levels take to the 11-turn 2.238-mile iconic road course at the Laguna Seca Recreation Area for an evening of two-wheeled fun and exercise. Twilight Cycling is one of the many community service-oriented programs that SCRAMP and Mazda Raceway Laguna Seca conduct.

The January ride is the first of 12 rides throughout the year and is scheduled to take place from 5-7 p.m. There is a \$10 entry fee per rider and helmets are required to participate.

Mazda Raceway Laguna Seca is the perfect place to train hard, ride for fun or do a little of both. Traffic flow is in one direction and 100 percent bicycles. There's the 180 feet of overall elevation change to test your stamina and the 18 percent downhill grade at Turn 8A, and overall 109-foot drop between Turns 8 and 9, to test your determination. Throw

in the spectacular rural Monterey County landscape and you have the perfect recipe for a great early evening of fun and exercise.

2017 Twilight Cycling Schedule

Jan. 18	Feb. 15
March 15	April 12
May 17	June 14
July 5,	Aug. 15 (Tues)
Sept. 20	Oct. 11
Nov. 8	Dec. 13

Ed: Now, is this not something we'd like to see at more of our race-tracks around North America? 🏁

Introducing



exclusive

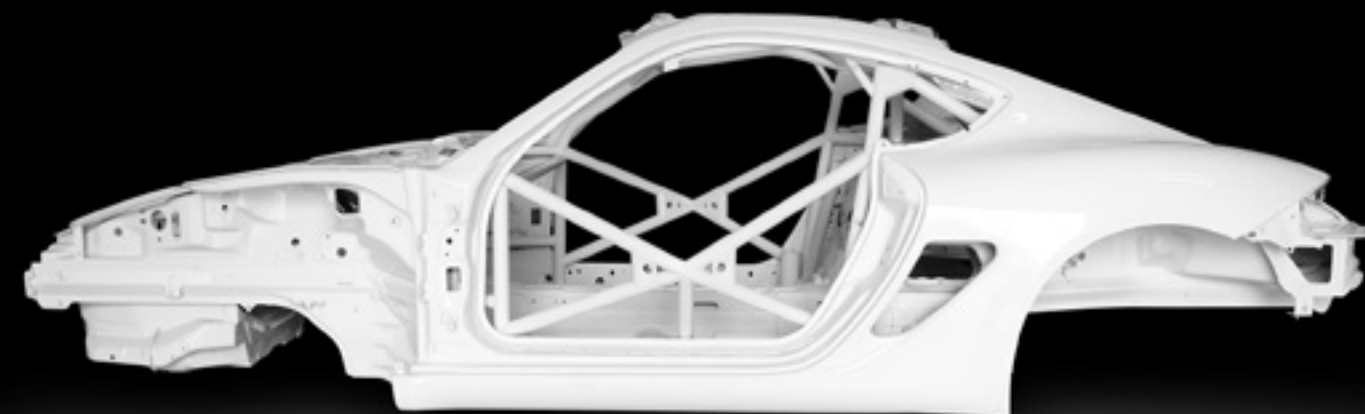

"Body In White" program

PERFECT START TO A RACE CAR PROJECT
OR REBUILD OF A CRASHED CAYMAN® RACE CAR

BRS rollcage tied in from front to rear strut towers

Can be sold with composite body panels

Acid dipped after rollcage installation

One in stock at all times

Base clear white paint



Bilt Racing Service
tel. (815) 582.7268
info@biltracingservice.com



2017 HARD CHARGERS

BY MICHAEL WINGFIELD, CHIEF OF NATIONAL TIMING & SCORING

Name	Region	Class	Description	Start	Finish	Index	Race
AUTO CLUB SPEEDWAY — APRIL 21-23							
Bob Jones	INT	F	S 87 911	24	12	12	Blue Sprint 1
Jeff Shulem	SBA	SPB	99 Boxster	30	18	12	Blue Sprint 1
Rusty West	SBA	SPB	97 Boxster	31	19	12	Blue Sprint 1
Walt Kaye	SDO	SPB	98 Boxster	33	21	12	Blue Sprint 1
Andres Hainer	LA	SPB	99 Boxster	17	8	9	Blue Sprint 2
Rich Yochum	RIV	GT3	02 Carrera	30	17	13	Green Sprint 1
Roland Schmidt	SDO	GT3	73 911	20	15	5	Green Sprint 2
Charles Wirken	AZ	GTD	16 GT4CS	7	5	2	Combined Sprint 3
Nigel Maidment	LA	SPB	99 Boxster	27	14	13	Combined Enduro
Leyvas/Oviatt	AZ	SPB	98 Boxster	29	16	13	Combined Enduro
BUTTONWILLOW RACEWAY PARK — MAY 27-28							
William Pickering	LPA	SPB	Spec 99 Boxster	18	11	7	Sprint Race 1
Andrew Forrest	GG	SPB	Spec 99 Boxster	19	12	7	Sprint Race 1
Doug Boccignine	DIA	SPB	Spec 97 Boxster	13	10	3	Sprint Race 2
Jack Mohn	LV	SP1	Spec 86 944	17	12	5	Sprint Race 3
GATEWAY MOTORSPORTS PARK — MAY 19-21							
David Varwig	CHO	GTD	16 GT4CS	7	6	1	Sprint Race 1
John Westra	CHO	GT4	75 911S	8	7	1	Sprint Race 1
Jim Vogel	CW1	I	S 14 Cayman S	10	9	1	Sprint Race 1
Chester Bailey	WIC	D	S 83 911S	13	12	1	Sprint Race 1
Bad Boyd	HCT	SP1	87 944	15	14	1	Sprint Race 1
Stephen Rosenberger	STL	D	S 78 911SC	9	6	3	Sprint Race 2
Dale Tuety	RMT	SP1	83 944	11	8	3	Sprint Race 2
Dale Tuety	RMT	SP1	83 944	10	6	4	Enduro Group B
HIGH PLAINS RACEWAY — JUNE 17-18							
Michael Hemmingway	RMT	SPB	98 Boxster	22	18	4	Yellow Sprint 1
Jeffrey Schmidt	SDO	GT4	97 993	16	13	3	Yellow Sprint 2
Dale Hartzell	RMT	GTA1	03 GT3 Cup	6	3	3	Orange Enduro
Mark Boschert	INT	SPB	99 Boxster	20	17	3	Orange Enduro
Walt/Kathy Fricke	RMT	D	S 82 911 SC	21	18	3	Orange Enduro
Dale Tuety	RMT	SP1	83 944	22	19	3	Orange Enduro
Mark Fenner	RMT	SP3	87 944S	23	20	3	Orange Enduro
LIME ROCK PARK — APRIL 21-22							
Jim Sherman	NNJ	SP3	86 951	24	18	6	White Sprint Race 1
Paolo Incampo	CTV	SPB	98 Boxster	16	9	7	White Sprint Race 2
John S Shafer	CTV	SP911	80 911 SC	18	13	5	Green Sprint Race 1
Harry Kintzi	CPA	F	P 01 Boxster S	14	5	9	Green Sprint Race 2
Bob Kim	NNJ	GTB3	06 997 Carrera S	17	11	6	Yellow Sprint Race 1
Michael Emblar	SCH	GTB1	12 Cayman	20	9	11	Yellow Sprint Race 2
Roger Funk	CTV	GT4	76 911	20	15	5	Orange Sprint Race 1
Leslie Shrem	NNJ	GT1	03 GT2	17	12	5	Orange Sprint Race 2

MID OHIO SPORTS CAR COURSE — MAY 5-7

Jim Child	OHV	SP3	94 968	14	4	10	Orange Sprint Race 1
Mark Peebles	FLC	SPB	98 Boxster	23	16	7	Orange Sprint Race 2
Robert Wisen	NCO	GTA2	09 GT3 Cup	4	1	3	Purple Sprint Race 1
Erik Winberg	MIL	GT1	05 GT3	5	1	4	Purple Sprint Race 2
Mike Origer	CHO	J	S 04 GT3	9	5	4	Purple Sprint Race 2
Jack Strifling	BGS	E	S 87 911	32	18	14	Combined Enduro
Michael Hemmingway	RMT	SPB	98 Boxster	36	22	14	Combined Enduro
Mark Peebles	FLC	SPB	98 Boxster	41	27	14	Combined Enduro

MOTORSPORTS PARK HASTINGS — JUNE 3-4

Chester Bailey	WIC	D	S 83 911 SC	13	9	4	Blue Sprint Race 1
Rachelle Butaud	LST	SPB	98 Boxster	16	9	7	Blue Sprint Race 2
Mark Steingas	NST	GTC3	05 GT3 Cup	6	2	4	Red Sprint Race 1
Mike Courtney	NST	GTC3	05 GT3 Cup	7	5	2	Red Sprint Race 2
David Byassee	RMT	SPB	99 Boxster	20	16	4	Combined Sprint 3

WATKINS GLEN INTERNATIONAL — JUNE 2-4

David Felker	RTR	SPB	99 Boxster	54	49	12	Blue Spring Race 1
Hoyt Ammidon	SCH	SPB	99 Boxster	44	27	17	Blue Sprint Race 2
Scott Plunkett	MSO	F	S 90 911	53	36	17	Blue Sprint Race 2
Chip Eggleton	GCT	E	S 78 911	14	11	3	Green Sprint Race 1
Mark Weining	DEL	E	S 82 911 SC Euro	18	14	4	Green Sprint Race 2
Joe Still	HOD	GTC4	09 911 GT3 Cup	39	26	13	Red Sprint Race 1
Leslie Shrem	NNJ	GT1	03 GT2	33	24	9	Red Sprint Race 2
Doug Fero	RTR	GTB1	08 Cayman S	41	28	13	Yellow Sprint Race 1
Matt Distefano	UPC	SPC	07 Cayman S	46	28	18	Yellow Sprint Race 2
Dennis Huffman	CHO	SP3	95 968 Firehawk	17	5	12	Orange Enduro
Tim McLean	CHO	SP3	89 944 S2	19	7	12	Orange Enduro
Randy Smith	UPC	SP2	97 944	23	11	12	Orange Enduro
Todd Lamb	PST	SPB	99 Boxster	24	10	14	Purple Enduro
Topher Everett	PST	SPB	99 Boxster	29	15	14	Purple Enduro
Dwayne Moses	POT	GTC3	03 GT3 Cup	12	4	8	White Enduro
Glenn Wiedenbeck	MAV	SP996	02 996	17	9	8	White Enduro
Ken Agena	SCH	J	S 04 GT3	18	10	8	White Enduro
Jean Audet	REN	K	04 GT3	21	13	8	White Enduro

MORE LAGUNA SECA TWILIGHT CYCLING (FROM PAGE 72)



The Classifieds

BUY, SELL AND BROWSE



"PurpleHaze" is for sale.

This 2009 Porsche Super Cup is a factory race car I have run PCA Club Racing in GTC4. All the right stuff. No expense spared. Performs perfectly. Podium results everywhere. The Haze has been managed by ToppRacing, altho' privateers can run these cars on their own. All accessories are included, 2 sets of BBS wheels, electronics, cooler, etc. Selling because I have moved on to the next chapter after motor racing.

Suggesting \$80,000.

FastFred (214) 212-6685 seipp@sbcglobal.net (18.1)

1994 968 E Class / SP3 Race Car

5 races on fresh motor & trans, custom airbox and Stahl header with custom exhaust, Behe chip, 944S2 flywheel, LSD, (4) CCW 18" wheels, Moton Club Sport shocks, M030 bars, Lexan windshield, fire system, removable steering wheel, 300# ballast removable for SP3, sorted, fast, ready to race.

\$30,000 Contact Mike biglickracing@aol.com (18.1)



2004 996 GT3 J Stock Champion

K-Fab 1.75 DOM roll cage, PCA legal nets, harness, halo seat on sliders... Moton Clubsport 2 way shocks with custom valving, serviced 2015... RSS suspension components, Numeric billet shifter, Aim data and camera... Fresh trans 2015 with fresh Guard diff... Fresh Bavaro built engine 2015 incl new wire harness... FVD exhaust, custom intake, cool suit system... 3 sets CCW race wheels 1 set stock GT3 wheels with new Hoosier rains... Many new or freshly serviced components. This car has been maintained and extensively developed by Bodymotion over the last few seasons. Many track records and countless class wins.

2016 PCA J class National Champ!

\$61,000 Geoff@bodymotion.com (732) 493-2700 (17.3)



FOR SALE — 2011 Cayman S (street car)

35K miles: silver/black, PDK w/sport chrono, limited slip diff, sport seats, design package (black accents), Boxster Spyder wheels, PCM Bose+nav, V1 radar, purchased and serviced at Circle Porsche in Long Beach, CA.

The car is located in Seal Beach, California. This vehicle is as well taken care of as a car can be. My wife and I have three cars and we just are not driving the Cayman enough to justify keeping it. We would like to see it go to a good home

All records, always garaged, \$39,000.

Contact Marty Goldsmith

captmarty@verizon.net (562) 494 6350



Package Deal: \$65,000.00 or individually

1998 Boxster Spec (SPB): 2016 CR Log Book, all proper components. Zero time engine, three event tranny w/new hardware & new 997 short-shift, new PSS-9 and springs, new side radiators. Custom exhaust (98 dB) & factory exhaust. Fire suppression, two seats & belts. Traqmate data logger with two cameras. Cool Suit, helmet blower, driver blower. Two sets of wheels (square) and one set (staggered). Sticker set Toyo RR (square) and sticker set Toyo RA1 (staggered). Second owner. Car build and driven by M. Essa and N. Richards. Maintained by Essa Autosport.

2010 Forest River/Cargo Mate 27' enclosed trailer:

5,200 lb axles, 4 wheel electric brakes, aluminum wheels, one year old, E-load tires. White vinyl walls, left & right side doors, upper cabinets and closet, toolbox, tire rack, folding bed/coach and removable table, 2nd bed that lifts to the ceiling. 50 amp electric circuit, 50 & 30 amp power cords, 110 lights and plugs (in & out), ONAN propane generator (5.5 kW), two deep cycle batteries. Air-conditioning and ceiling fan/vent. TV, stereo, microwave, small refrigerator, back-up camera, LED lights, nitrogen bottle and air lines. ANDERSEN anti-sway hitch and ball.



1980 911 Euro, GT3 Class or PCA Vintage

Car built with consultation from The Racer's Group, 993 complete fiberglass body panels, 2200#, 3.4L twin plug engine with 3 hrs. on rebuild, 50mm PMO's (details available on request) G50-20 6 speed race trans. 2-sets Fikse FM-5 18" wheels, JRZ triple adjustable coil over suspension, complete EHP suspension components, Porsche big reds, Tilton master cylinders, TRG fuel cell, Halon fire system, Racetech halo seat, No expense spared,

\$58,000 OBO for complete details Contact : Denny Wasser @ 610-781-7631 or denn_wasser12@comcast.net (18.1)

2005 FORD F-250 Lariat Super Duty 4WD: 80k miles. 8 cyl, 6.0 L turbodiesel, automatic, Off Road package, modest lift, towing package, aluminum wheels & spare, new tires, all the options. Complete BANKS system with IQ dash and engine brake (CARB approved). Rear air suspension, rear view camera. Climate control, custom stereo (CD/DVD). Dealer service.

Vehicles and trailer located in Huntington Beach, CA. More info available upon request.

Contact: nickperdi@gmail.com

text or call: (310) 901-8154

(18.1)

A QUICK GLANCE



I had the good fortune to make my first trip to Watkins Glen this year. Special thanks to Pete Tremper for his extra effort to make my job easier and more productive.

One of these included knowing the whoops to jump through (who to ask) to get me credentialed to be in the start/finish tower. This was one of the best places I saw to take photos (and be real close to the action).

We know that The Glen is the oldest track in the U.S., and if you had any doubts that their workers lack experience, just check out the patches on the starter's jacket!



National Committee

Club Racing Chair

Vicki Earnshaw
7161 South Lewis Street, Littleton, CO 80127
720.244.1532
vicklm@aol.com

Club Racing Co-chair & Chief Steward

Bryan Henderson
2416 Bedford Circle, Bedford, TX 76021-1822
817.845.2664 (fax) 817.345.6045
Bryan@BPHMS.com

Program & License Coordinator

Susan Shire
1897 Mission Hills Lane, Northbrook, IL 60062-5760
847.272.7764 (fax) 847.919.6862
PCAClubRace@aol.com

Chief Scrutineer

Mike Mulligan
1304 North Melrose Drive, Suite B, Vista, CA 92083
760.672.9175
Mugs914@yahoo.com

Chief of Timing & Scoring

Michael Wingfield
3805 Clearwater Court, Plano, TX 75025-2094
972.491.2766
Wingfield@juno.com

Technical & Rules Coordinator

Walt Fricke
4651 Huey Circle, Boulder, CO 80305
303.499.6540
WalterFricke@msn.com

Sponsor Coordinator

Vu Nguyen
P.O.Box 6400, Columbia, MD 21045
410.381.0911
ExecutiveDirector@pca.org

Printing

Innovative Printing Solutions
SolutionsDianna@aol.com
760.420.1950

Copyright 2017 / Porsche Club of America

ADVERTISER INDEX

Apex Performance	25
Austin Motorsports	69
Autometrics	51
BBS Wheels	BC
Bodymotion	33
BRS / LN Engineering	73
CARQUIP	59
Chizmark Larson Insurance	70
Club Racing National Sponsors	52
COBB Tuning	55
CSF Radiators	67
CupCar Solutions	51
Demon Speed Motorsports	65
EBS Racing	57
Forgeline	53
Hollinger	45
Hubstands	41
JX2 Performance Group	39
KW Suspension	10
Locton HPDE Insurance	21
Millers Oils	37
Moton Suspension Technology	36
Northstar Motorsports	IFC
OG Racing	IBC
PFC Brakes	27
Red Line Oil	65
Slide Rule Motorsport / Zimiki Coaching	59
Softronic	7
Stable Energies	71
Strategies for Wealth	21
Sube Sports	49
TC Racing	77
TOYO Tires	15
Traqgear	67

CLUB RACING NEWS

Editor

Skip Carter
10385 Bonnie Lane, La Mesa, CA 91941
619.992.9927
SkipCarter@pobox.com

Advertising Coordinator

Ilko Nechev
5030 Broadway #825, New York, NY 10034
646.644.2796
ilko@pca.org



1.800.934.9112 | www.ogracing.com

OG RACING

Got Brakes?

The OG-Racing PFC Guarantee

It's easy. We're so sure that you'll like PFC's pad compounds that we're going to guarantee it! Buy a set of PFC pads and try them out for a weekend - if you don't like them, we'll exchange them for the Pagid or Hawk pads of your choice (or equivalent store credit). Visit the link below for all the details.



Learn more: ogracing.com/performance-friction-brakes

Program Details: PFC Brake Pad Guarantee applies to any purchase of current PFC pad compounds, shapes & applications. Discontinued or special order part numbers are not eligible for this program. Pads must be returned after ONE event or within 30 days (whichever comes first). Pads may be exchanged for an equivalent Pagid or Hawk shape OR OG-Racing Store Credit up to the purchase price of the returned pads. Other terms or limitations may apply. OGR Inc reserves the right to cancel or modify this program at any time and for any reason.

BBS

Technik aus dem Motorsport



Many Championship Winning Teams Choose BBS.
Shouldn't You? Never Compromise



991 GT3 CH-R CL
Coming August 2017

Congratulations Porsche on your 24 Hours of Le Mans Win!

BBS of America, Inc. | 800-422-7972 | www.bbs-usa.com

#raceproven

